





UNC Workgroup Report	At what stage is this document in the process?
<h1>UNC 0714:</h1> <h2>Amendment to Network Entry Provision at Perenco Bacton Terminal</h2>	<div style="display: flex; flex-direction: column; gap: 5px;"> <div style="border: 1px solid green; border-radius: 5px; padding: 2px; display: flex; align-items: center; gap: 5px;"> 01 Modification </div> <div style="border: 1px solid blue; border-radius: 5px; padding: 2px; display: flex; align-items: center; gap: 5px;"> 02 Workgroup Report </div> <div style="border: 1px solid purple; border-radius: 5px; padding: 2px; display: flex; align-items: center; gap: 5px;"> 03 Draft Modification Report </div> <div style="border: 1px solid orange; border-radius: 5px; padding: 2px; display: flex; align-items: center; gap: 5px;"> 04 Final Modification Report </div> </div>
<p>Purpose of Modification:</p> <p>This Modification will enable the current Wobbe Index lower limit that applies between National Grid and Perenco at Bacton to be temporarily reduced from 47.2 MJ/m³ to 46.5 MJ/m³.</p>	
	<p>The Workgroup recommends that this modification should be reconsidered by the Panel as to whether it should be subject to self-governance</p> <p>The governance route for the proposal is further discussed in the Workgroup Impact Assessment in Section 6</p> <p>The Panel will consider this Workgroup Report on <u>21 May</u> 2020. The Panel will consider the recommendations and determine the appropriate next steps.</p>
	<p>High Impact:</p>
	<p>Medium Impact:</p> <p>GB gas transporters, interconnector operators, shippers, consumers</p>
	<p>Low Impact:</p>

Deleted: 2

Deleted: 29

Contents	
1 Summary	3
2 Governance	3
3 Why Change?	4
4 Code Specific Matters	5
5 Solution	5
6 Impacts & Other Considerations	6
7 Relevant Objectives	9
8 Implementation	10
9 Legal Text	10
10 Recommendations	11
11 Appendices	12

Timetable	
Modification timetable:	
Initial consideration by Workgroup	06 February 2020
Workgroup Report v1.0 presented to Panel	16 April 2020
Workgroup Report v2.0 presented to Panel	21 May 2020
Draft Modification Report issued for consultation	21 May 2020
Consultation Close-out for representations	11 June 2020
Final Modification Report available for Panel	16 June 2020
Modification Panel decision	16 July 2020
Ofgem decision (if required)	20 August 2020

Any questions?

Contact:
Joint Office of Gas Transporters

enquiries@gasgovernance.co.uk

0121 288 2107

Proposer:
Riccardo Rossi
Centrica Energy Limited

riccardo.rossi@centrica.com

telephone

Transporter:
National Grid

philip.hobbins@nationalgrid.com

telephone

Systems Provider:
Xoserve

UKLink@xoserve.com

Other:
Tracy Brogan

Tracy.Brogan@neptuneenergy.com

telephone

Deleted: 10

Deleted: 11

Deleted: 2

Deleted: 29

1 Summary

What

This is an enabling Modification to facilitate a temporary amendment to the Wobbe Index lower limit within the Network Entry Provisions between Perenco and National Grid at Bacton. It is proposed to reduce the limit from 47.2 MJ/m³ to 46.5 MJ/m³.

Why

Gas produced from the Cygnus field has a Wobbe Index around 1% below the existing Gas Safety (Management) Regulations, (GS(M)R), lower limit, but within the emergency limit. Blending upstream of entry to the NTS is utilised to enable this new gas field to produce and deliver gas into the gas transmission network. However, since commissioning, Cygnus production loss due to insufficient blend gas availability has been significant, and this loss is projected to increase from early 2021. Alternative upstream blending and treatment solutions will not be available in the same timeframe to mitigate impacts.

Deleted: mid-2020

The impacts include significant loss of lower cost, lower carbon UKCS natural gas to UK consumers and a threat to the ability to Maximise the Economic Recovery of this largest single gas field in the UK in addition to that of other more mature gas fields in the Southern North Sea.

How

The Proposer is seeking to amend the Network Entry Provision described above via this enabling Modification. The proposed limit of 46.5 MJ/m³ is below the GS(M)R lower limit, therefore gas with a Wobbe Index within the range of 46.5 MJ/m³ and 47.2 MJ/m³ would only be accepted into the National Grid terminal where a compliant blend of gases can be achieved.

2 Governance

Justification for Authority Direction

The Modification was previously assessed as requiring Authority Direction due to potential competition impacts as, subject to Health and Safety Executive, (HSE), approved exemption to GS(M)R being granted, gas with Wobbe Index below the existing lower limit could flow to downstream connected parties.

The effect of this amended Modification on competition is no longer deemed material due to the restricted time period it applies for and that appropriate mitigations will be put in place such that the risk of non-compliant gas reaching consumers or downstream connected parties is not increased.

No other pipeline incomers entering the NTS at Bacton have gas sources below the existing GS(M)R Wobbe Index lower limit, therefore this amendment will not unduly discriminate. The ability to flow gas outwith the Wobbe Index GS(M)R limit would not apply at any other NTS entry point as a result of this proposal being implemented, however should any other party wish to apply for such an arrangement at any other location it would be free to raise its own proposal and each case would be assessed on its own merits. Existing upstream commercial arrangements for blend gas supply will also remain unchanged.

Deleted: 2

Deleted: 29

Requested Next Steps

This Modification should:

- be considered a non-material change and subject to self-governance
- be assessed by a Workgroup

A significant, extended upstream infrastructure outage is planned to start in May 2021, limiting blend gas availability for the Cygnus supply. The proposed timeframe recognises the significant commercial impact on Cygnus and downstream infrastructure owners and the potential benefit for consumers if an amendment can be made prior to this outage.

Note: At the April Workgroup, the proposed conversion of the proposal to self-governance was discussed. The majority of Workgroup participants that expressed a view judged that the proposal should continue to follow an Authority Decision governance route, the rationale being set out in Section 6.

Deleted: August 2020

3 Why Change?

Driver for change

The Cygnus field, owned by Neptune Energy (Operator) and Spirit Energy, is located in a previously underdeveloped area of the Southern North Sea. Cygnus Alpha started production in December 2016 and Cygnus Bravo in August 2017, with gas exported through a new 50km extension to the existing 165km ETS pipeline to Perenco's gas terminal at Bacton.

The Cygnus gas exported to Bacton has a Wobbe Index in the range of 46.6 to 46.8 MJ/m³. It commingles within the ETS pipeline with gas from Trent and Tors fields and, at sales conditions, this stream will generally range from 46.5 to 46.7 MJ/m³ and above. There are five gas pipelines flowing into the Perenco terminal (see Appendix I schematic), with all four others meeting NTS specification. Fortuitous blending takes place with gas from these fields within the Perenco terminal. In addition, a 'blend line' links the SEAL reception facilities in the neighbouring terminal and there is contractual access to a proportion of gas from this source for supplemental blending. No further infrastructure exists to link to any other gas sources in the Bacton area. The higher-pressure arrival of gas from the ETS pipeline results in the potential for a greater proportion of Cygnus gas to fill the common facilities during moments of pressure reduction on other incoming pipelines, including during pig receipt and offshore unplanned outage. To mitigate the risk of shut-in of all on-spec fields - due to gas below 47.2 MJ/m³ in the terminal unable to be received by National Grid - an additional Wobbe Index margin above 47.2 MJ/m³ is required to be met. This is managed by an automated gas quality control system, whereby on rate of change of reducing Wobbe Index on the common terminal outlet, control valves progressively close on the ETS pipeline to reduce and finally enact full shut-in of the pipeline at 47.45 MJ/m³. This system clearly also takes action in the event of reduction or loss of blend gas source.

Extended and shorter duration (planned and unplanned) offshore and onshore outages in 2017 to 2020 have resulted in frequent production curtailment and shut-in of the Cygnus field. This is of concern to the Oil and Gas Authority (OGA) as stewards of MER UK.

Deleted: 2019

The situation is set to deteriorate in 2021 with planned outage of upstream infrastructure in Q2, which will significantly impact Cygnus production for up to forty (40) days. Following this extended outage, one of the two offshore SEAL producing hubs will reroute gas from Bacton to St Fergus. Combined with the declining rates and availability of more mature blend fields, the ongoing availability of blend gas for Cygnus from existing arrangements and infrastructure has the potential to reduce appreciably.

Deleted: 0

Deleted: 3

Deleted: at

Deleted: least

Deleted: 2

Deleted: 29

Collaboration between the Cygnus owners, the OGA and all Bacton infrastructure owners has been strong to date and continues in order to further increase contractual access to remaining SEAL volumes for blending, prior to ~~2021~~. This will limit impact when this source is available but not resolve the issue. Other solutions explored include facilities modification to tie-in to additional sources of gas at Bacton, National Grid blending service and nitrogen removal facilities; however, these options are not achievable within the coming year. Propane injection onshore has also been considered but discounted on grounds of safety and practicality.

Deleted: Q3

Deleted: 0

Potential Impact

Ongoing and increasing production loss from the Cygnus field has several effects. During the planned infrastructure outage in Q2 ~~2021~~ alone, the reduction in lower cost, lower carbon gas to the UK from the Cygnus field alone could range from 94 to >350 MCM. Production loss will add to this on an ongoing basis from Q2 ~~2021~~, when connected sources of blend gas at Bacton reduce. Increased UKCS gas and reduced reliance on imported sources is recognised to have the positive effect of applying downward pressure on wholesale gas price and benefit security of supply.

Deleted: 3

Deleted: 0

Deleted: 3

Deleted: 0

The limitations affecting the field has delayed further investments and will likely continue to do so if the framework does not evolve.

4 Code Specific Matters

Reference Documents

Link to: [Gas Safety \(Management\) Regulations \(GS\(M\)R\) 1996](#)

Knowledge/Skills

No additional knowledge/skills, above those available, required to assess this Modification.

5 Solution

This Modification seeks to amend the Network Entry Provision between Perenco and National Grid at Bacton for a specified time period of not more than 40 consecutive days starting not earlier than 1st ~~May 2021~~ and not later than ~~30th June 2021~~. It is proposed to reduce the Wobbe Index lower limit from 47.2 MJ/m³ to 46.5 MJ/m³ for this period subject to the conditions set out below.

Deleted: August

Deleted: 0

Deleted: 31st August 2020

Formatted: Superscript

Gas with Wobbe Index from 46.5 to 47.2 MJ/m³ from the Perenco terminal incomer at Bacton National Grid terminal will be accepted provided sufficient higher Wobbe Index gas is available to blend, such that National Grid is able to ensure that all feeders that convey gas away from its terminal and all connected parties at Bacton (Great Yarmouth power station, IUK, BBL and the Cadent DN offtake) receive gas with a WI \geq 47.2 MJ/m³. Flows can be configured within the pipework arrangement at NG Bacton to route available on-spec gas to commingle with gas from the Perenco terminal at the earliest opportunity on entry to NG terminal. If insufficient gas is available to ensure the existing GS(M)R limits for all feeders and offtakes are met, the allowable Perenco terminal flow will be reduced and, if necessary, cease immediately via the Transportation Flow Advice process.

Under normal circumstances, with all fields that deliver gas into the Perenco terminal online, the WI of gas leaving the Perenco terminal is expected to be above 47.2 MJ/m³ (in the range 47.17 to 47.62 MJ/m³). The range of expected WI with one of four on-spec offshore hubs completely offline is 47.03 to 47.35 MJ/m³. Less

Deleted: 2

Deleted: 29

than 1 MCM/day would be required to blend from 47.0 MJ/m³, with around ten times this rate generally available. In a worst-case scenario with Cygnus only flowing from the Perenco terminal, 3.5 MCM/day would be required to ensure the NG terminal remained GS(M)R compliant. It is intended that the required flow rates and Wobbe Index of on-spec gas will be continually monitored by National Grid such that any reduction below the minimum flow required will trigger immediate curtailment action of Perenco supplies before blending occurs, thereby ensuring that no gas with a Wobbe Index lower than 47.2 MJ/m³ penetrates into the NG terminal beyond the point at which the relevant gas streams meet.

6 Impacts & Other Considerations

Does this Modification impact a Significant Code Review (SCR) or other significant industry change projects, if so, how?

No impact identified.

Consumer Impacts

A benefit to consumers through downward pressure on gas prices could result, through increased UKCS gas flow. Security of supply would be facilitated by enabling ongoing supply from the largest single gas field in the UK, capable of providing up to 6% of UK demand, when other upstream sources are offline.

If this proposal is implemented, the calorific value of gas entering the NTS at Bacton is expected to be lower than would otherwise be the case. However, analysis carried out by National Grid, and presented to the Workgroup in March 2020, indicated a low likelihood of flow weighted average CV capping occurring as a consequence and hence a low risk that consumers would be charged materially differently to the energy received.

The presentation on CV Shrinkage due to CV capping can be found here: [Modification 0714: CV Shrinkage Analysis](#), and shows the CV Flow Weighted Average values across all LDZs for a Base Case and 3 further flow scenarios, each scenario has a high flow case and a low flow case, analysed at two points in time; Gas Years 2019/20 and 2025/26.

The principal conclusion of the analysis is that Scenarios 1 & 3 do have the potential to give rise to CV Shrinkage due to CV capping, although these scenarios represent flow configurations which are more hypothetical than likely to occur in practice. Furthermore, this analysis was completed based on a previous version of the Modification which contemplated National Grid being granted an exemption from the HSE to allow sub-GS(M)R Wobbe Index gas onto the NTS pipelines. With the proposal having been amended to blend any gas in the Wobbe range 46.5 – 47.2 MJ/m³ within the NG terminal such that only GS(M)R compliant gas would be made available for offtake by consumers, Scenarios 1 and 3 are no longer applicable because there would be no source of blend gas for the Cygnus flows in those scenarios meaning that any such gas would not be admitted into the NG terminal. Scenario 2, which assumes 46.5 MJ/m³ Wobbe Index for Perenco inputs and 2019 average Wobbe Indexes for all other Bacton supplies, is the most realistic flow configuration and remains relevant for the amended solution. This scenario does not give rise to CV Shrinkage due to CV capping as a result of factors pertaining to Bacton flows. (Any CV Shrinkage due to CV capping that could occur would be due to inputs from biomethane delivery facilities.)

Consumer Impact Assessment

(Workgroup assessment of proposer initial view or subsequent information)

Criteria	Extent of Impact
Which Consumer groups are affected?	The proposed National Grid within-terminal blending solution should have no effect on consumers. While the solution proposed carries a marginal rise in inherent risk for a small sub-set of consumers whose connections are embedded within the National Grid terminal, the contractual arrangements would permit the deployment of operational flow management tools between National Grid and Perenco to mitigate this risk.
What costs or benefits will pass through to them?	No costs would pass through to consumers. Such that there any directly attributable operational costs, these would be contained within the organisations in which they occur.
When will these costs/benefits impact upon consumers?	N/A
Are there any other Consumer Impacts?	None identified

General Market Assumptions as at December 2016 (to underpin the Costs analysis)

Number of Domestic consumers	21 million
Number of non-domestic consumers <73,200 kWh/annum	500,000
Number of consumers between 73,200 and 732,000 kWh/annum	250,000
Number of very large consumers >732,000 kWh/annum	26,000

Cross Code Impacts

No impact identified.

EU Code Impacts

No impact identified.

Central Systems Impacts

No impact identified.

Workgroup Impact Assessment

Discussion at the Workgroup, in the context of the “blending solution” that this Modification now proposes, is summarised below:

Governance

The latest version of the proposal has been redrafted to advocate Self-governance, which prompted a significant debate of the merits, and counter-points of pursuing self-governance. The collective Workgroup provided two schools of thought, which are summarised below:

Of those supporting self-governance, the view was that in terms of gas exiting the National Grid terminal and terminal-embedded oftakes, they would be no more likely than now to receive sub-GS(M)R specification gas and that the inherent increased risk of this occurring could be resolved operationally, with modified and enhanced operating procedures between National Grid and Perenco. The new operating procedures would be coupled with National Grid rights to curtail flows from the Perenco terminal in the event that there was insufficient blend gas available. As such, the view was this was a low risk solution which would, in any event, be time-limited and therefore is not expected to have a material effect in respect of the self-governance criteria.

Of those not supporting the self-governance route, the points was that for this arrangement to occur, the HSE would need to be consulted, with a potential need for a temporary derogation for National Grid from its Safety Case covering the entry specification of the gas entering the National Grid terminal at the Perenco entry point. Sub-GS(M)R specification gas is not normally permitted to flow into a National Grid terminal and such a unique arrangement should be considered by Ofgem & the HSE, potentially requiring HSE approval for the arrangements prior to an Ofgem decision on the Modification.

On balance, of those expressing an opinion, the view was that the proposal should adopt a governance route that concludes with Authority Direction.

Operational Matters

The Workgroup were very keen to understand the operational details that would permit the blending solution to be delivered.

National Grid explained that the sub-GS(M)R specification gas would only be permitted into its terminal under strict operational controls. For the gas to flow, National Grid operational staff at Bacton would have to be satisfied that there was sufficient blend gas available to ensure that the co-mingled stream of gas leaving the terminal was within GS(M)R specification, and where there was a risk that this could not be achieved, the Perenco stream would be either restricted to ensure a compliant blend, or curtailed entirely where flows could not be managed to provide a compliant output. The Workgroup was advised that the National Grid gas quality measurement equipment monitoring the specification of the Perenco gas entering had a reporting interval of 2.5 - 3 minutes, which should allow the gas flows entering the NTS to be managed to be within specification with an appropriate level of control, provided the measures that are more specifically described below are implemented.

National Grid proposes to determine the required flow-rate and Wobbe Index of the relevant on-spec gas stream based on a fixed 'worst case' Perenco flow and Wobbe Index scenario (i.e. a high flow-rate and Wobbe Index assumption of 46.5 MJ/m³). Whenever Perenco are delivering gas with a Wobbe Index between 46.5 and 47.2 MJ/m³, monitoring shall take place check against a pre-defined assessment of whether there is sufficient flow and Wobbe Index from the on-spec stream to deliver a compliant blend. This pre-defined assessment shall also include a suitable tolerance that accounts for flow metering and gas quality measurement uncertainty.

National Grid also proposes to install additional alarms onto its DCS control system on the instantaneous repeat telemetry signals that are received from the relevant on-spec gas stream in order to alert Bacton shift staff / Gas National Control Centre, (GNCC), that there is a risk of insufficient blend gas and that curtailment action may shortly be required, if Perenco are at that time flowing in the range 46.5 – 47.2 MJ/m³. This will minimise the human factor risk of non-compliant gas arriving in the NGG terminal undetected and allow an operator more time to take action, if necessary. National Grid also proposes to install 'low Wobbe Index' alarms set just above 47.2 MJ/m³ on the NTS pipelines to alert Bacton shift staff that the blend of gases may be approaching non-compliance.

Relevant National Grid procedures will be updated to document what action should be taken in the event that on-spec flows reduce below the minimum requirement, Perenco flow within the 46.5 MJ – 47.2 MJ/m³ range and if low Wobbe Index within the GS(M)R range is detected on an NTS pipeline leaving the National Grid terminal. National Grid will also seek to put in place formalised and documented procedures which clearly articulate differing accountabilities, roles and responsibilities of all parties (NGG Bacton / GNCC / Perenco).

National Grid will require the ability to suspend the arrangement and reinstate the 47.2 MJ/m³ Wobbe Index requirement with Perenco in the event that its ability to meet its obligations is threatened by other factors which may include any relevant equipment malfunction, infrastructure failure or emergency situation.

There was a general view that these safeguards mitigated participant concerns that non-GS(M)R specification would exit the National Grid terminal and would be further mitigated given the time limited arrangement proposed.

Given these proposed controls and operational safeguards, and in contrast with the prevailing arrangement where the Cygnus contribution to the Perenco gas inputs may simply not have been permitted to enter the terminal during the forthcoming upstream outage period, the National Grid view was there should be no greater risk of off-spec gas leaving the terminal than is currently the case, subject to the necessary procedures being agreed with Perenco. The operation of this temporary blending service would also provide National Grid some valuable operational experience and could pave the way for further commercial blending services.

In conclusion, National Grid asked the Workgroup if they had any fundamental issue with what was trying to be achieved and allowing this stream of gas to flow through the terminal.

None of those who replied expressed a view that the initiative should not be proceed and most welcomed National Grid were exhibiting a degree of pragmatism and flexibility in working with the relevant parties towards the proposed solution. This was caveated by one respondent who stated that it would be acceptable, provided any costs arising from the revised work procedures did not fall on a wider customer base, (and would be contained between the parties accruing the benefit) and by another who stated that the obligations and upon whom they fall are clear.

7 Relevant Objectives

Impact of the Modification on the Relevant Objectives:

Relevant Objective	Identified impact
a) Efficient and economic operation of the pipe-line system.	Positive
b) Coordinated, efficient and economic operation of (i) the combined pipe-line system, and/ or	None

(ii) the pipe-line system of one or more other relevant gas transporters.	
c) Efficient discharge of the licensee's obligations.	None
d) Securing of effective competition: (i) between relevant shippers; (ii) between relevant suppliers; and/or (iii) between DN operators (who have entered into transportation arrangements with other relevant gas transporters) and relevant shippers.	Positive
e) Provision of reasonable economic incentives for relevant suppliers to secure that the domestic customer supply security standards... are satisfied as respects the availability of gas to their domestic customers.	None
f) Promotion of efficiency in the implementation and administration of the Code.	None
g) Compliance with the Regulation and any relevant legally binding decisions of the European Commission and/or the Agency for the Co-operation of Energy Regulators.	None

The implementation of this proposal would better facilitate the following Relevant Objectives:

- a) The efficient and economic operation of the pipeline system is positively impacted by this Modification because it would facilitate additional volumes of gas to be processed through the existing network infrastructure than would otherwise be the case. One Workgroup participant offered a counter-view that the proposed solution would require more National Grid resource to develop and operate which could lead to less efficient system operation.
- d) At the same time, the proposal will secure greater flexibility in the transportation of gas allowing more sources to be 'eligible' to enter the NTS; Securing of effective competition between Shippers would be better facilitated by maximising available UKCS production into the NTS. Greater supply diversity would result in more shippers bringing gas to the UK and making the NBP more competitive.

8 Implementation

The Proposer is seeking implementation by July 2020 in order to facilitate contractual and operational activities ahead of the extended blend gas outage in ~~Q2 2021~~.

- Deleted: ne
- Deleted: August
- Deleted: 2020.

9 Legal Text

As this is an enabling Modification, (in accordance with UNC Transportation Principal Document Section I paragraph 2.2.3 (a)), no UNC text changes are required; implementation would enable National Grid NTS and Perenco to temporarily amend the Wobbe Index limit, which is constituted within the Network Entry Provisions that apply between the parties.

- Deleted: 2
- Deleted: 29

10 Recommendations

Workgroup's Recommendation to Panel

The Workgroup asks Panel to:

- reconsider the decision for making the proposal Authority Direction, in light of the suggestion made by the proposer and the documented discussion at the Workgroup, and
- to consider the Workgroup's recommendation that the proposal proceeds to consultation.

Deleted: 2

Deleted: 29

Appendices

Appendix I – Bacton Terminals schematic

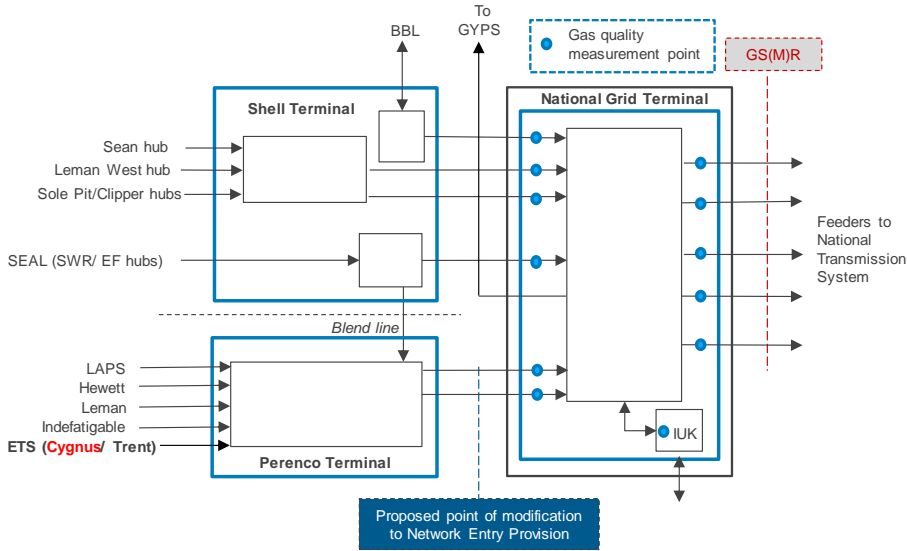

Appendix II – Bacton Terminals Aerial photograph

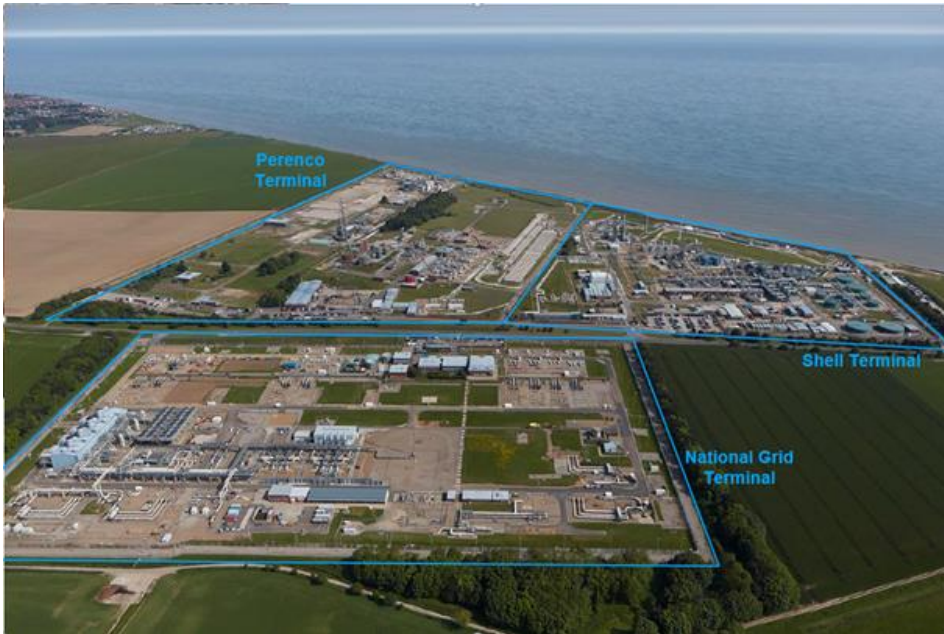

Deleted: 2

Deleted: 29