

**UNC Workgroup 0691S Minutes  
CDSP to convert Class 2, 3 or 4 meter points to Class 1 when  
G1.6.15 criteria are met**

**Tuesday 26 November 2019**

**at Radcliffe House, Blenheim Court, Warwick Road, Solihull B91 2AA**

**Attendees**

Rebecca Hailes (Chair)	(RH)	Joint Office
Karen Visgarda (Secretary)	(KV)	Joint Office
Andy Clasper	(AC)	Cadent
David Mitchell	(DM)	SGN
Derek Clark	(DC)	Contract Natural Gas
Fiona Cottam	(FC)	Xoserve
James Rigby	(JR)	Xoserve
Kirsty Dudley*	(KD)	E.ON
Laura Claringbold	(LC)	Contract Natural Gas
Lorraine O'Shaughnessy	(LO)	Joint Office
Lorna Lewin*	(LL)	Orsted
Louise Hellyer	(LH)	Total Gas & Power
Luke Reeves*	(LR)	EDF Energy
Mark Bellman	(MB)	Scottish Power
Mark Jones*	(MJ)	SSE
Mark Palmer*	(MP)	Orsted
Megan Coventry*	(MC)	SSE
Naomi Anderson	(NA)	Utility Warehouse
Oorlagh Chapman*	(OC)	British Gas
Rhys Kealley	(RK)	British Gas
Richard Pomroy*	(RP)	Wales & West Utilities
Rob Johnson*	(RJ)	Waters Wye Associates
Rose Kimber	(RKi)	Contract Natural Gas
Ryan Stephenson	(RS)	Utility Warehouse
Stephanie Clements*	(SC)	Scottish Power

*\*via teleconference*

Copies of all papers are available at: <http://www.gasgovernance.co.uk/0691/261119>

The Workgroup Report is due to be presented at the UNC Modification Panel by 20 February 2020.

**1. Introduction and Status Review**

The meeting was confirmed to be quorate.

**1.1. Approval of Minutes (22 October 2019)**

The minutes from the previous meeting were approved.

**2. Amended Modification v5.0**

Rhys Kealley (RK) provided a draft of a further amended Modification V.6.2 which had been submitted at the start of the meeting. Rebecca Hailes (RH) reminded all participants of the 5 day rule, which is that all meeting papers need to be submitted so as to allow at least 5 days for the documents to be read by all attendees.

RK explained that he had been studying the overall UNC process and he had come across some questions that he could not answer and so wanted to overview the alterations in the Modification.

He then overviewed the amended Modification and drew attention to the Solution section, especially in relation the flow diagram and the overall process in relation to the CDSP, as detailed below:

Figure 1: Existing timeline for change to Class 1

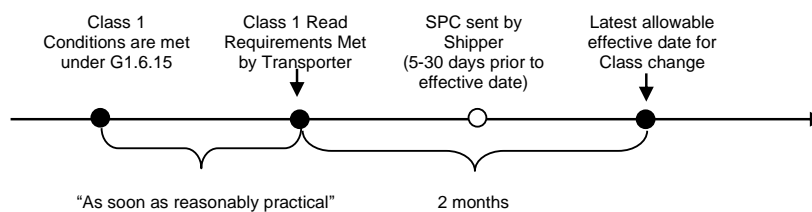
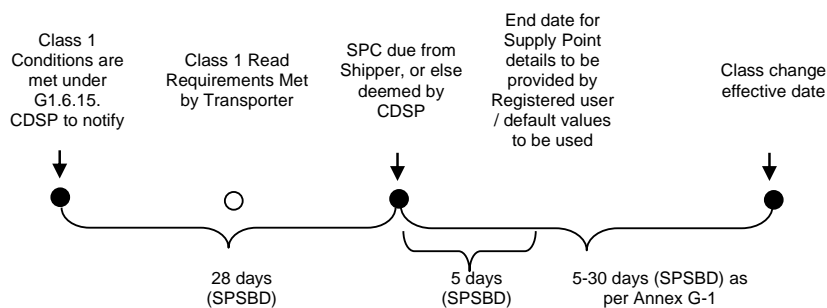

Figure 2: Proposed timeline for change to Class 1



A lengthy general discussion then ensued and Louise Hellyer (LH) said the biggest issue was getting the equipment installed on site in the first instance, regarding access and the challenging timelines to enable the CDSP to effect the change. Richard Pomroy (RP) concurred with this comment.

Fiona Cottam (FC) said that it was perfectly possible for Class 2 site to move to be in Class 1 and then estimate a read in Class 1.

A further discussion then took place regarding the legality of the process in relation to what the Class 1 meter reads requirements were, as per TPD Section G. 1.5.4.

AMR suitability was generally discussed, noting that it would likely not deliver the service, there was the issue of who was responsible for it, there was no follow up process, and that more detail was needed behind the Class 1 process. RK said that all comments were helpful and that he would amend the flow diagram accordingly.

David Mitchell (DM) asked if it was possible to determine the number of sites that did have DN Read equipment already installed and then they could specifically target these to resolve the issue. FC said that as of 26 November there were 15 sites in that category.

Mark Bellman (MB) proposed that perhaps a trial could be arranged with one or two of those sites and the Shippers/Suppliers to see how easy it was address. LH reiterated once again that the equipment did need to be installed to enable a site to move to Class 1.

RP said that perhaps this could be included in the DSC Service Line, and that it would need to be included with the Modification. James Rigby (JR) said that for it to be included in the DSC Service Line, a detailed report would be required, and this would need to be included in the MPRN1 & 2. RH said in that case, JR and RK should work together to define what was needed.

**New Action 1101:** Xoserve (JR) and British Gas (RK) to specify what detail needed to be included in the PARR Report (A and B versions) in relation to the implementation and the DSC Service Line.

### 3. Consideration PARR Report specification/format

RK said that this area was being discussed with Xoserve in relation to the solution.

### 4. Legal Text provision and review

DM said that the draft Legal Text was in production and would be soon be ready to be shared, once the amended Modification v7.0 had been submitted.

### 5. Confirmation of whether or not an equivalent IGT Modification was required (November)

RK confirmed that an IGT Modification would not be required and Kirsty Dudley (KD) concurred with this statement, however she added that if the Legal Text was changed then an IGT Modification would be needed and this was the same situation with regards to *Modification 0690S – Reduce qualifying period for Class 1*.

### 6. Finalise Workgroup Report

RH said that the Workgroup Report would be developed and reviewed at the December meeting.

### 7. Review of Outstanding Actions

**0901:** Xoserve and British Gas to consider XRN4958 and raise a Change Proposal to provide the specification for the required PARR Report for Modification 0691S.

**Update:** FC and RK requested this action was carried forward. **Carried Forward.**

**0902:** PAC Members (CW/LH/MB) to ensure the specification of the new PARR Reports for Modification 0691S is considered by the Performance Assurance Committee (PAC).

**Update:** RK requested that this action was carried forward. **Carried forward.**

**Action 1001:** RK to submit an amended Modification ~~v5.0~~. v7.0

**Update:** RK requested that this action was carried forward as he would be submitting a further amended Modification v7.0. **Carried forward**

**Action 1002:** Legal Text to be provided for Modification 0691S based on ~~v5.0~~. V7.0

**Update:** DM and RK requested this action was carried forward. **Carried forward**

**Action 1003:** Proposer (RK) to raise a Change Proposal for Modification 0691S.

**Update:** RK requested this action was carried forward. **Carried forward**

### 8. Next Steps

RH outlined the next steps as follows:

- Amended Modification v7.0 (December)
- Consideration PARR Report specification/format (December)

- Legal Text provision and review (December)
- Confirmation of whether an equivalent IGT Modification is required (December)
- Finalisation of Workgroup Report (December / January 2020)

**9. Any Other Business**

None.

**10. Diary Planning**

Further details of planned meetings are available at: [www.gasgovernance.co.uk/events-calendar/month](http://www.gasgovernance.co.uk/events-calendar/month)

Workgroup meetings will take place as follows:

Time / Date	Venue	Workgroup Programme
10:30 Thursday 12 December 2019	Radcliffe House, Blenheim Court, Warwick Road, Solihull B91 2AA	<ul style="list-style-type: none"> <li>• Review Amended Modification v7.0 (December)</li> <li>• Consideration PARR Report specification/format (December)</li> <li>• Legal Text provision and review (December)</li> <li>• Confirmation of whether an equivalent IGT Modification is required (December)</li> <li>• Finalisation of Workgroup Report (December / January 2020)</li> </ul>

**Action Table (as at 26 November 2019)**

Action Ref	Meeting Date	Minute Ref	Action	Owner	Status Update
0901	23/09/19	2.0	Xoserve and British Gas to consider XRN4958 and raise a Change Proposal to provide the specification for the required PARR Report for Modification 0691S.	Xoserve /British Gas (FC/RK)	<b>Carried Forward</b>
0902	23/09/19	2.0	PAC Members (CW/LH/MB) to ensure the specification of the new PARR Reports for Modification 0691S is considered by the Performance Assurance Committee (PAC).	PAC (CW/LH/MB)	<b>Carried Forward</b>
1001	22/10/19	2.0	RK to submit an amended Modification v5.0.	British Gas (RK)	<b>Carried Forward</b>
1002	22/10/19	2.0	Legal Text to be provided for Modification 0691S based on v5.0.	SGN (DM)	<b>Carried Forward</b>
1003	22/10/19	2.0	Proposer (RK) to raise a Change Proposal for Modification 0691S.	British Gas (RK)	<b>Carried Forward</b>

1101	26/11/19	2.0	Xoserve (JR) and British Gas (RK) to specify what detail needed to be included in the PARR Report (A and B versions) in relation to the implementation and the DSC Service Line.	Xoserve (JR)/ British Gas (RK)	<b>Pending</b>
------	----------	-----	--	--------------------------------	----------------