

Stage 02: Workgroup Report

0400:

Removal of obligation to install duplicate Telemetry Equipment

Removal of the obligation to install duplicate telemetry equipment at an offtake where there are no requirements for NTS control facilities.



The Workgroup recommends that this self-governance modification should now proceed to Consultation



High Impact:
N/A



Medium Impact:
N/A



Low Impact:
National Grid Transmission and the Distribution Transporters

What stage is this document in the process?



0400

Workgroup Report

20 December 2011

Version 1.0

Page 1 of 15

© 2011 all rights reserved

Contents

- 1 Summary
- 2 Why Change?
- 3 Solution
- 4 Relevant Objectives
- 5 Impacts and Costs
- 6 Implementation
- 7 The Case for Change
- 8 Legal Text
- 9 Recommendation

About this document:

The purpose of this report is make a recommendation to the Panel, to be held on 19 January 2012, on whether Modification 0400 is sufficiently developed to proceed to consultation and to submit any further recommendations in respect of the definition and assessment of this self-governance modification.



3 **Any questions?**

4 Contact:

6 **Joint Office**



8 **Enquiries@gasgo**
9 **vernance.co.uk**



12 **0121 623 2115**

13 Proposer:

14 **Dave Corby**



15 **David.Corby@uk.**
ngrid.com



01926 654912

Transporter:

National Grid
Transmission

0400

Workgroup Report

20 December 2011

Version 1.0

Page 2 of 15

© 2011 all rights reserved

1 Summary



Is this a Self Governance Modification?

The Modification Panel determined that this is a self-governance modification.

Why Change?

The Enduring Distribution Networks Arrangements (EDNA) Project Team was established by Transporters to discuss what arrangements were required to manage the interface arrangements between the Transmission and the Distribution Network Operator (DNO) systems post System Operator Managed Service Agreement (SOMSA).

Currently, at the majority of off-takes, the DNOs own the telemetry equipment and pass data to National Grid Transmission (NGT) electronically. However, the UNC currently obligates NGT to install their own duplicate Telemetry Facilities when the existing DNO equipment reaches the end of its service life.

One of the proposals made by the EDNA Project Team was that it would be more economic and efficient if duplicate NTS Physical Telemetry Facilities are only installed at an offtake by NGT when NGT's requirements cannot be met by the DNO Telemetry Facilities.

Solution

This modification proposes to change the Offtakes Arrangement Document (OAD) section E2.3.5 so that NGT are only required to install telemetry equipment where they have identified that it is operationally necessary and efficient to do so. Measurement data will continue to be provided by DNO telemetry equipment via DNO systems.

Impacts & Costs

No costs will be incurred in the implementation of the proposal. NGT anticipates a significant benefit to its capital expenditure by avoiding the cost to the industry of installing duplicate telemetry outstation and connection facilities.

Implementation

No IS systems changes have been identified as required to support the implementation of this Modification Proposal.

The Case for Change

Removing the obligation on NGT to install duplicate telemetry equipment in all cases will lead to significant savings in Telemetry Equipment contributing to the economic and efficient operation of the pipeline system.

Recommendations

The Workgroup considers that the self-governance modification is sufficiently developed and should now proceed to consultation.

What is a Point of Telemetry?

A Point of Telemetry is a data item relating to connection facilities or gas flowing at an NTS / LDZ Offtake.

See OAD Section E 1.2.1(d)

2 Why Change?



What is a SCADA?

Under the OAD, SCADA (Supervisory Control and Data Acquisition) is an electronic link between the DNO's systems and NGT's systems.

See E 1.2.1 (a) (ii)

To align UNC with operational requirements

The EDNA Project Team was established by Transporters to discuss what arrangements were required to manage the interface arrangements between the Transmission and the DNO systems post System Operator Managed Service Agreement (SOMSA). The EDNA Project Team identified a number of improvements that should be made for the enduring regime, one of which is being addressed through this Modification.

At the point of Network Sales, the existing telemetry equipment become the property of the DNO and requirements were established for that telemetry equipment to report the relevant measurement data to the NGT system via DNO systems and a SCADA link, see diagram 1:

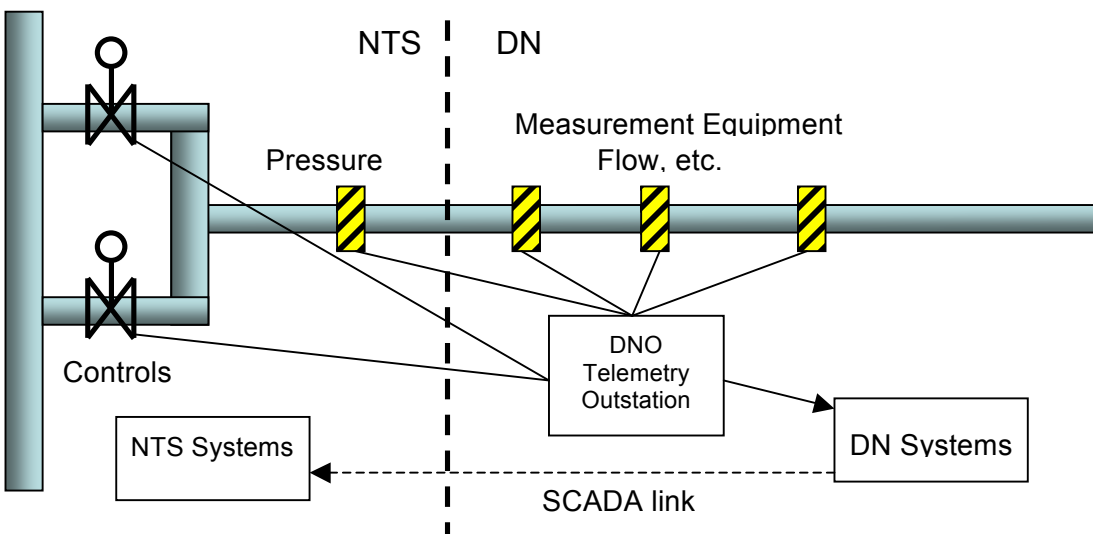

Diagram 1: Telemetry equipment at point of network sales.

The original drafting of the OAD required NGT to install its own telemetry outstation and connection facilities at all offtakes by the close of the SOMSA project, as illustrated in diagram 2:

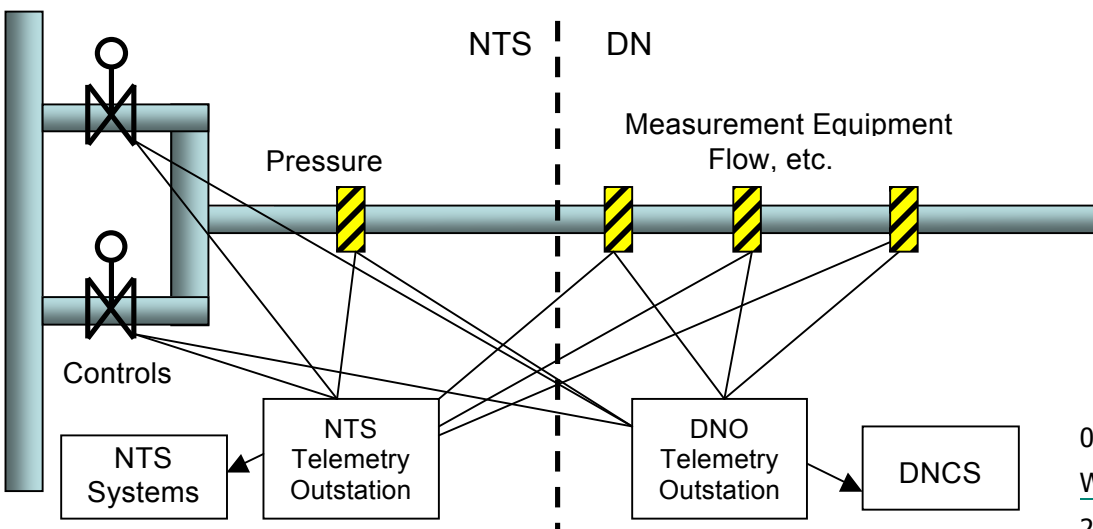

Diagram 2: Duplicate Telemetry equipment installed as per original drafting of OAD.

Due to the impracticality of installing NTS telemetry equipment at every offtake by the end of the SOMSA project, Mod 0207 was implemented to defer the requirement for NTS to install telemetry facilities until the time at which the DNO telemetry equipment reaches the end of its service life. Because the revised timescale is now variable, and often results in significant time before NTS equipment is installed, Mod 0207 also recognised the SCADA link as a robust solution for telemetry data to be provided to NTS.

One of the proposals made by the EDNA Project Team was that, as the Distribution Network Control System (DNCS) represents a thoroughly robust route for reporting of measurement data, the obligation to install duplicate NGT physical telemetry equipment is inefficient and uneconomic where the NGT telemetry requirements at the offtake do not include controls.

3 Solution

This Modification proposes to change the OAD, Section E 2.3.5 such that NGT is no longer obligated to install duplicate NTS Physical Telemetry Facilities at all offtakes.

3.1 Control Facilities

Since the implementation of Mod 0207, a number of sites have had NTS telemetry installed. The significant costs and complexity associated with linking either both outstations to all measurement equipment (see diagram 2), or alternatively linking the two outstations to each other to share the telemetry, has resulted in a revised operational design that linked the NTS outstation solely to NTS assets and the DN outstation solely to DN assets.

This modification proposes that the OAD be changed to recognise the revised operational telemetry arrangements where control facilities are required by NGT at the offtake. Under this revised arrangement the NGT telemetry equipment only connects to the NTS controls and measurement data is provided to NGT via DNO systems (diagram 3):

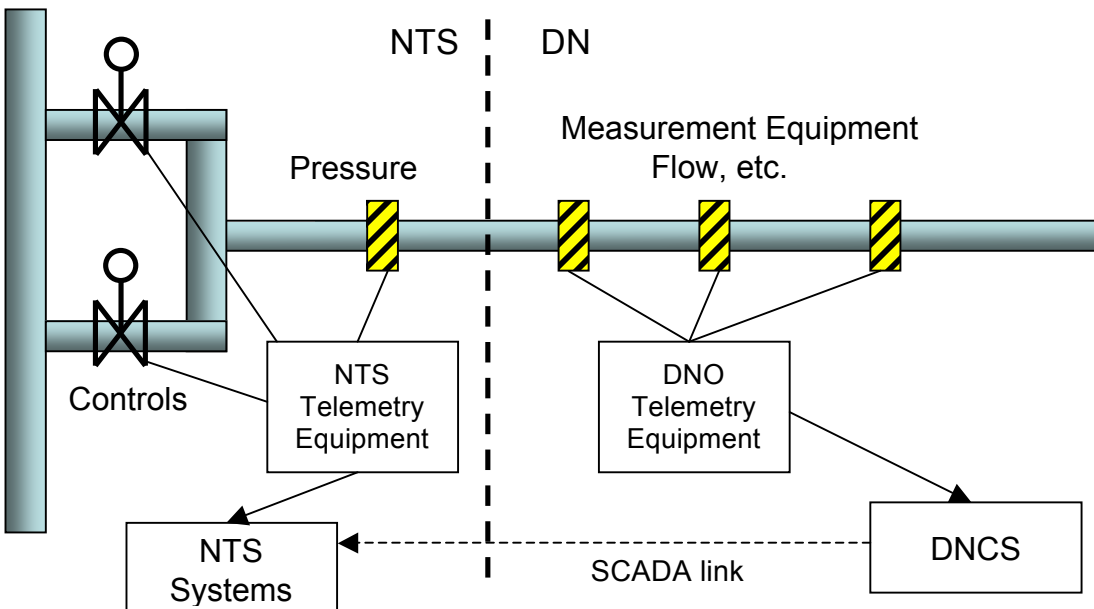

Diagram 3: Telemetry equipment in line with operational design.

3.2 No Control Facilities

At the time of writing, NGT does not require remote control facilities at approximately 60 out of the current 122 offtakes, and it is proposed that NGT will not be obliged to install NTS Physical Telemetry Facilities at these offtakes. This modification proposes that the DNO continues to provide the required measurement data for these offtakes via DN systems. See diagram 4, below.

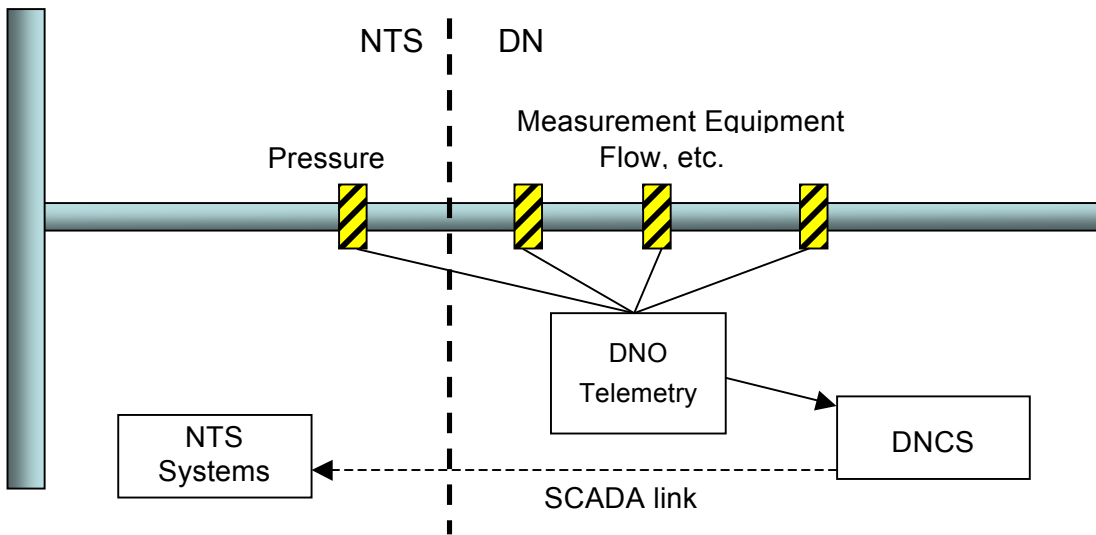

Diagram 4: Proposed telemetry equipment where no NTS controls are necessary.

This modification proposes by association that some NTS data (e.g. inlet pressure) will be provided to the NTS via DN telemetry equipment and systems. Legacy arrangements mean that telemetry connections facilities to DN outstations should already exist where necessary.

For the avoidance of doubt, the modification proposal does not change NGT's entitlement to install NTS Physical Telemetry Facilities as per OAD Section E 2.3.1 to 2.3.4. As mentioned earlier, NGT will still be required to install telemetry outstations and connection facilities where control purposes are identified.

4 Relevant Objectives

Implementation is expected to better facilitate the achievement of **Relevant Objective b: Coordinated, efficient and economic operation of the pipeline system.**

Proposer's view of the benefits against the Code Relevant Objectives

Description of Relevant Objective	Identified impact
a) Efficient and economic operation of the pipe-line system.	None
b) Coordinated, efficient and economic operation of (i) the combined pipe-line system, and/ or (ii) the pipe-line system of one or more other relevant gas transporters.	Improves economic operation of the NGT pipe-line system.
c) Efficient discharge of the licensee's obligations.	None
d) Securing of effective competition: (i) between relevant shippers; (ii) between relevant suppliers; and/or (iii) between DN operators (who have entered into transportation arrangements with other relevant gas transporters) and relevant shippers.	None
e) Provision of reasonable economic incentives for relevant suppliers to secure that the domestic customer supply security standards... are satisfied as respects the availability of gas to their domestic customers.	None
f) Promotion of efficiency in the implementation and administration of the Code	None
g) compliance with the Regulation and any relevant legally binding decisions of the European Commission and/or the Agency for the Co-operation of Energy Regulators	None

Coordinated, efficient and economic operation of the pipeline system

The removal of the obligation on NGT to provide duplicate telemetry equipment in all cases will lead to significant Capital Expenditure savings in telemetry equipment costs to the industry. This reduction in costs naturally contributes to the economic and efficient operation of the pipeline system.

5 Impacts and Costs

Consideration of Wider Industry Impacts

Costs

Indicative industry costs – User Pays
No costs identified.

Impacts

Impact on Transporters' Systems and Process	
Transporters' System/Process	Potential impact
UK Link	None
Operational Processes	None
User Pays implications	None

Impact on Users	
Area of Users' business	Potential impact
Administrative and operational	None
Development, capital and operating costs	Reduction of development costs.
Contractual risks	None
Legislative, regulatory and contractual obligations and relationships	None

Impact on Transporters	
Area of Transporters' business	Potential impact
System operation	The proposal facilitates the realisation of CAPEX savings to the industry, anticipated to be approximately £9M, which is in-line with NGT's RIIO submission.
Development, capital and operating costs	Reduction in development and CAPEX costs.
Recovery of costs	Reduction in development costs.
Price regulation	None
Contractual risks	None

Impact on Transporters	
Legislative, regulatory and contractual obligations and relationships	None
Standards of service	None

Impact on Code Administration	
Area of Code Administration	Potential impact
Modification Rules	None
UNC Committees	None
General administration	None

Impact on Code	
Code section	Potential impact
Offtakes Arrangements Document, Section E 2.3.5	As described in Section 3 of this document.

Impact on UNC Related Documents and Other Referenced Documents	
Related Document	Potential impact
Network Entry Agreement (TPD I1.3)	None
Network Exit Agreement (Including Connected System Exit Points) (TPD J1.5.4)	None
Storage Connection Agreement (TPD R1.3.1)	None
UK Link Manual (TPD U1.4)	None
Network Code Operations Reporting Manual (TPD V12)	None
Network Code Validation Rules (TPD V12)	None
ECQ Methodology (TPD V12)	None
Measurement Error Notification Guidelines (TPD V12)	None
Energy Balancing Credit Rules (TPD X2.1)	None
Uniform Network Code Standards of Service (Various)	None

Impact on Core Industry Documents and other documents	
Document	Potential impact
Safety Case or other document under Gas Safety (Management) Regulations	None
Gas Transporter Licence	None

Other Impacts	
Item impacted	Potential impact
Security of Supply	
Operation of the Total System	
Industry fragmentation	
Terminal operators, consumers, connected system operators, suppliers, producers and other non code parties	

6 Implementation

In September 2011 the Modification Panel determined this modification should follow self-governance procedures.

As self-governance procedures are proposed, implementation could be 16 business days after a Modification Panel decision to implement.

7 The Case for Change

In addition to that identified the above, the Proposer has identified the following:

Advantages

The modification promotes the economic operation of pipe-lines at the Offtake from NGT's network to the DNO's networks by relieving the requirement to always install NTS duplicate telemetry equipment and thereby reducing costs.

Disadvantages

None identified.

8 Legal Text

Suggested Legal Text:

OAD Section E

Amend paragraph 2.3.5 to read as follows:

2.3.5 Where the NTS Telemetry Facilities in respect of an Offtake are NTS Electronic Telemetry Facilities, and the equipment (other than Telemetry Connection Facilities) provided by the DNO and utilised by such NTS Electronic Telemetry Facilities for the sending and receiving of signals to and from the Measurement Equipment and/or the National Grid NTS Connection Facilities ("Equipment") reaches the end of its service life, then National Grid ~~may~~ shall install NTS Physical Telemetry Facilities at the Offtake and connect such facilities (via the Telemetry Connection Facilities) to the Measurement Equipment. For the avoidance of doubt, the provisions of paragraph 2.3 shall apply to such NTS Physical Telemetry Facilities.

The equipment referred to above (the "**Equipment**") will be deemed to have reached the end of its service life on the earliest of the following:

- (a) the date on which a Reasonable and Prudent Operator would choose to routinely replace the Equipment having regard to its age and condition; or
- (b) the date on which the Equipment fails and is beyond economic repair; or
- (c) on such date as otherwise agreed between National Grid NTS and the DNO, such agreement not being unreasonably withheld.

9 Recommendation

The Workgroup invites the Panel to:

- AGREE that Modification 0400 be submitted for consultation.