

Stage 04: Final Modification Report

0400S:

Removal of obligation to install duplicate Telemetry Equipment

At what stage is this document in the process?



Removal of the obligation to install duplicate telemetry equipment at an offtake where there are no requirements for NTS control facilities.



Panel determined to implement the modification.



High Impact: -



Medium Impact: -



Low Impact: National Grid Transmission and the Distribution Transporters

0400S

Final Modification Report

19 April 2012

Version 2

Page 1 of 17

© 2012 all rights reserved

Contents

1	Summary	
2	Why Change?	
3	Solution	
4	Relevant Objectives	
5	Impacts and Costs	
6	Implementation	
7	The Case for Change	
8	Legal Text	
9	Consultation Responses	
10	Panel Discussions	Error! Bookmark not defined.
11	Recommendations	



3 Any questions?

**4 Contact:
Joint Office**

6  **enquiries@gasgo
8 vernance.co.uk**

9  **0121 623 2115**

**13 Proposer:
13 Dave Corby**

14  **David.Corby@uk.
15 ngrid.com**

17  **01926 654912**

Transporter:
**National Grid
Transmission**

About this document:

This document is a Final Modification Report, presented to the Panel on 19 April 2012.

The Panel will consider the views presented and decide whether or not this self-governance change should be made.

0400S

Final Modification Report

19 April 2012

Version 2

Page 2 of 17

© 2012 all rights reserved

1 Summary

Is this a Self-Governance Modification?

The Modification Panel determined that this is a self-governance modification.

Why Change?

The Enduring Distribution Networks Arrangements (EDNA) Project Team was established by Transporters to discuss what arrangements were required to manage the interface arrangements between the Transmission and the Distribution Network Operator (DNO) systems post System Operator Managed Service Agreement (SOMSA).

Currently, at the majority of off-takes, the DNOs own the telemetry equipment and pass data to National Grid Transmission (NGT) electronically. However, the UNC currently obligates NGT to install its own duplicate Telemetry Facilities when the existing DNO equipment reaches the end of its service life.

One of the proposals made by the EDNA Project Team was that it would be more economic and efficient if duplicate NTS Physical Telemetry Facilities were only installed at an offtake by NGT when NGT's requirements cannot be met by the DNO Telemetry Facilities.

Solution

This modification proposes to change the Offtakes Arrangement Document (OAD) section E2.3.5 so that NGT are only required to install telemetry equipment where they have identified that it is operationally necessary and efficient to do so. Measurement data will continue to be provided by DNO telemetry equipment via DNO systems.

Impacts and Costs

No costs will be incurred in the implementation of the modification. NGT anticipates a significant benefit to its capital expenditure by avoiding the cost to the industry of installing duplicate telemetry outstation and connection facilities.

Implementation

No IS systems changes have been identified as required to support the implementation of this modification.

As self-governance procedures are proposed, implementation could be 16 business days after a Modification Panel decision to implement.

The Case for Change

Removing the obligation on NGT to install duplicate telemetry equipment in all cases will lead to significant savings in Telemetry Equipment contributing to the economic and efficient operation of the pipeline system.



What is a Point of Telemetry?

A Point of Telemetry is a data item relating to connection facilities or gas flowing at an NTS / LDZ Offtake.

See OAD Section E 1.2.1(d)

2 Why Change?



To align UNC with operational requirements

The EDNA Project Team was established by Transporters to discuss what arrangements were required to manage the interface arrangements between the Transmission and the DNO systems post System Operator Managed Service Agreement (SOMSA). The EDNA Project Team identified a number of improvements that should be made for the enduring regime, one of which is being addressed through this modification.

At the point of Network Sales, the existing telemetry equipment become the property of the DNO and requirements were established for that telemetry equipment to report the relevant measurement data to the NGT system via DNO systems and a SCADA link, see Diagram 1:

What is a SCADA?

Under the OAD, SCADA (Supervisory Control and Data Acquisition) is an electronic link between the DNO's systems and NGT's systems.

See E1.2.1(a)(ii)

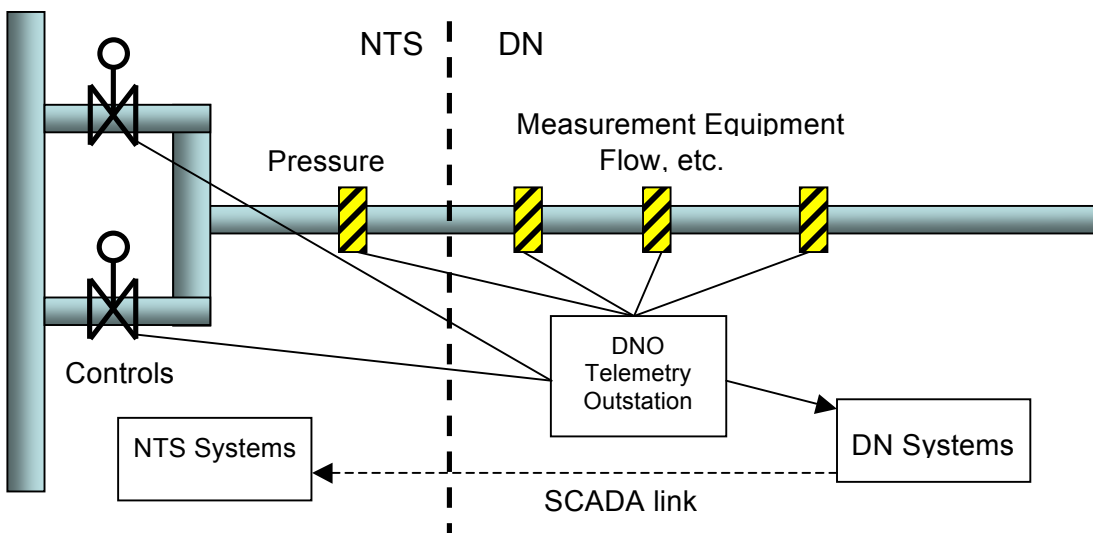

Diagram 1: Telemetry equipment at point of network sales.

The original drafting of the OAD required NGT to install its own telemetry outstation and connection facilities at all offtakes by the close of the SOMSA project, as illustrated in Diagram 2:

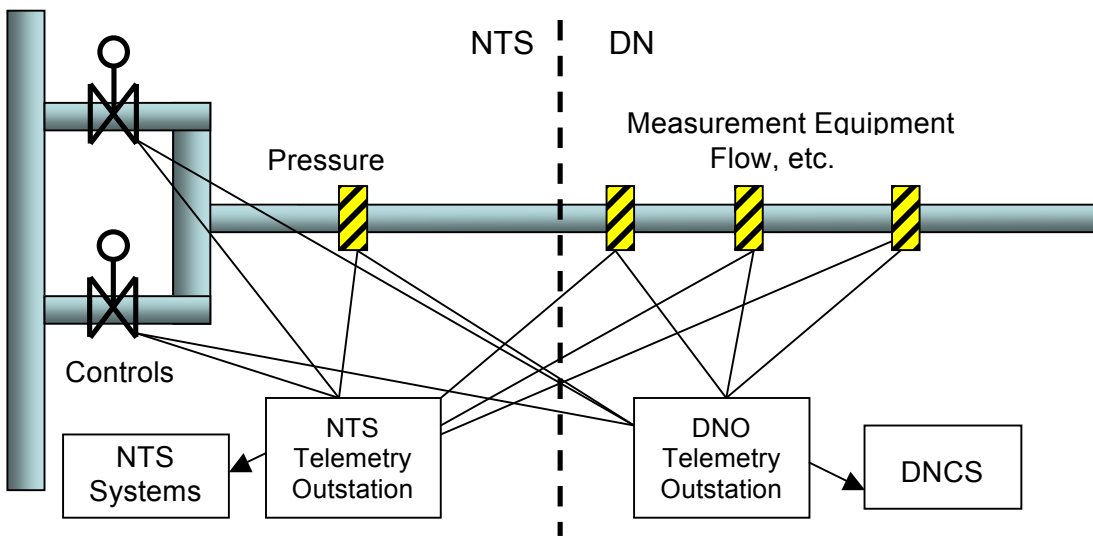

Diagram 2: Duplicate Telemetry equipment installed as per original drafting of OAD.

Due to the impracticality of installing NGT telemetry equipment at every offtake by the end of the SOMSA project, Modification 0207 was implemented to defer the requirement for NGT to install telemetry facilities until the time at which the DNO telemetry equipment reaches the end of its service life. Because the revised timescale is now variable, and often results in significant time before NGT equipment is installed, Modification 0207 also recognised the SCADA link as a robust solution for telemetry data to be provided to NGT.

One of the proposals made by the EDNA Project Team was that, as the Distribution Network Control System (DNCS) represents a thoroughly robust route for reporting of measurement data, the obligation to install duplicate NGT physical telemetry equipment is inefficient and uneconomic where the NGT telemetry requirements at the offtake do not include controls.

3 Solution

This Modification proposes to change the OAD, Section E 2.3.5 such that NGT is no longer obligated to install duplicate NTS Physical Telemetry Facilities at all offtakes.

3.1 Control Facilities

Since the implementation of Mod 0207, a number of sites have had NTS telemetry installed. The significant costs and complexity associated with linking either both outstations to all measurement equipment (see diagram 2), or alternatively linking the two outstations to each other to share the telemetry, has resulted in a revised operational design that linked the NTS outstation solely to NTS assets and the DN outstation solely to DN assets.

This modification proposes that the OAD be changed to recognise the revised operational telemetry arrangements where control facilities are required by NGT at the offtake. Under this revised arrangement the NGT telemetry equipment only connects to the NTS controls and measurement data is provided to NGT via DNO systems (diagram 3):

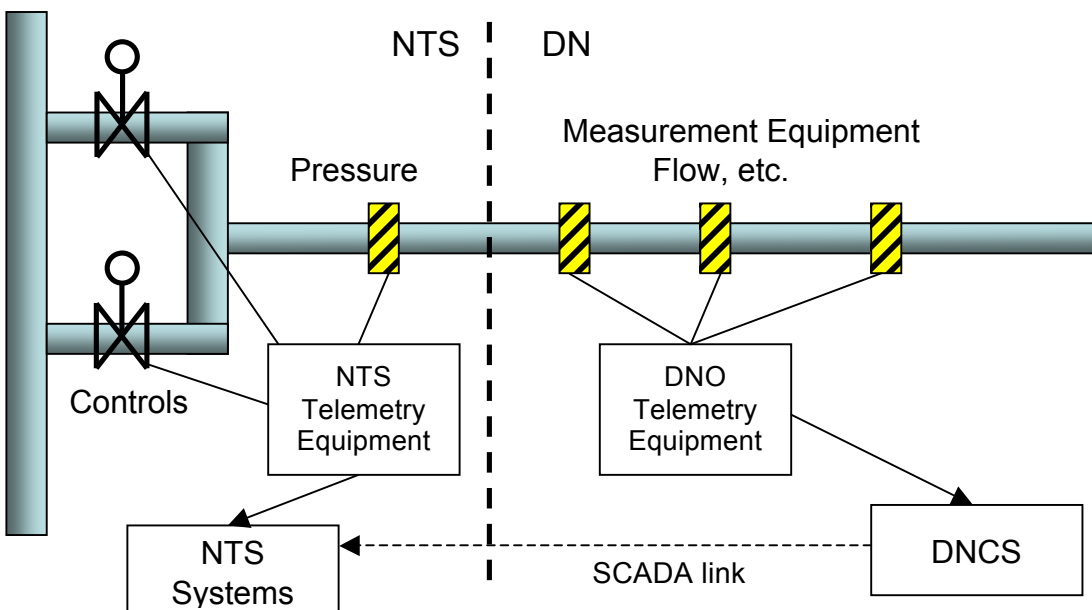

Diagram 3: Telemetry equipment in line with operational design.

3.2 No Control Facilities

At the time of writing, NGT does not require remote control facilities at approximately 60 out of the current 122 offtakes, and it is proposed that NGT will not be obliged to install NTS Physical Telemetry Facilities at these offtakes. This modification proposes that the DNO continues to provide the required measurement data for these offtakes via DN systems. See diagram 4, below.

0400S

Final Modification Report

19 April 2012

Version 2

Page 6 of 17

© 2012 all rights reserved

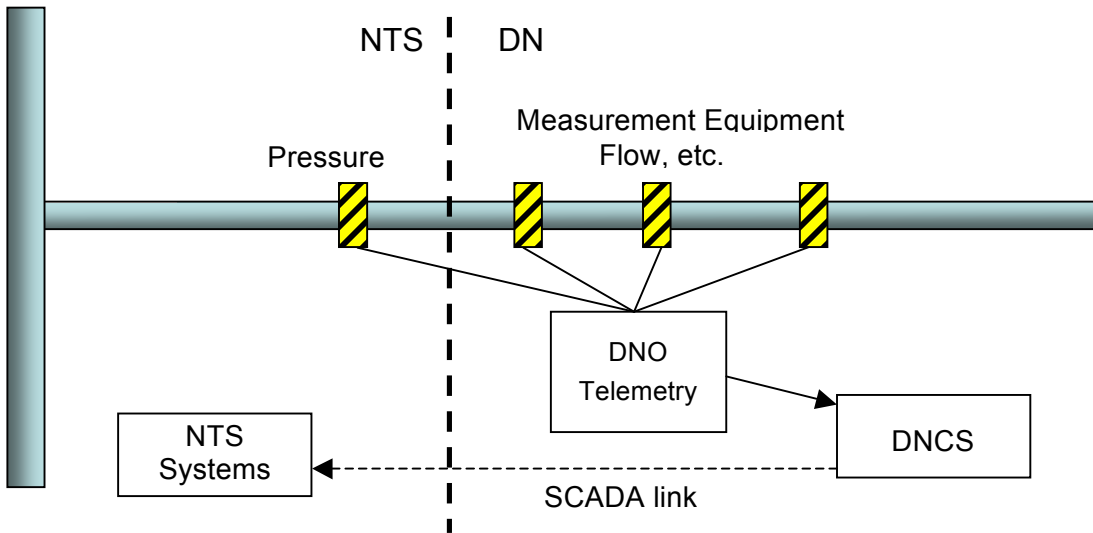

Diagram 4: Proposed telemetry equipment where no NTS controls are necessary.

This modification proposes by association that some NTS data (e.g. inlet pressure) will be provided to the NTS via DN telemetry equipment and systems. Legacy arrangements mean that telemetry connections facilities to DN outstations should already exist where necessary.

For the avoidance of doubt, the modification proposal does not change NGT's entitlement to install NTS Physical Telemetry Facilities as per OAD Section E 2.3.1 to 2.3.4. As mentioned earlier, NGT will still be required to install telemetry outstations and connection facilities where control purposes are identified.

4 Relevant Objectives

Impact of the modification on the Relevant Objectives:	
Description of Relevant Objective	Identified impact
a) Efficient and economic operation of the pipe-line system.	None
b) Coordinated, efficient and economic operation of (i) the combined pipe-line system, and/ or (ii) the pipe-line system of one or more other relevant gas transporters.	Improves economic operation of the NGT pipe-line system.
c) Efficient discharge of the licensee's obligations.	None
d) Securing of effective competition: (i) between relevant shippers; (ii) between relevant suppliers; and/or (iii) between DN operators (who have entered into transportation arrangements with other relevant gas transporters) and relevant shippers.	None
e) Provision of reasonable economic incentives for relevant suppliers to secure that the domestic customer supply security standards... are satisfied as respects the availability of gas to their domestic customers.	None
f) Promotion of efficiency in the implementation and administration of the Code.	None
g) Compliance with the Regulation and any relevant legally binding decisions of the European Commission and/or the Agency for the Co-operation of Energy Regulators.	None

b) Coordinated, efficient and economic operation of the pipeline system

The removal of the obligation on NGT to provide duplicate telemetry equipment in all cases will lead to significant Capital Expenditure savings in telemetry equipment costs to the industry. This reduction in costs naturally contributes to the economic and efficient operation of the pipeline system.

5 Impacts and Costs

Consideration of Wider Industry Impacts

None identified.

Costs

Indicative industry costs – User Pays
Classification of the Proposal as User Pays or not and justification for classification
No costs identified.
Identification of Users, proposed split of the recovery between Gas Transporters and Users for User Pays costs and justification
N/A
Proposed charge(s) for application of Users Pays charges to Shippers
N/A
Proposed charge for inclusion in ACS – to be completed upon receipt of cost estimate from Xoserve
N/A

Impacts

Impact on Transporters' Systems and Process	
Transporters' System/Process	Potential impact
UK Link	<ul style="list-style-type: none"> None
Operational Processes	<ul style="list-style-type: none"> None
User Pays implications	<ul style="list-style-type: none"> None

Impact on Users	
Area of Users' business	Potential impact
Administrative and operational	None
Development, capital and operating costs	Reduction of development costs.
Contractual risks	None
Legislative, regulatory and contractual obligations and relationships	None

Where can I find details of the UNC Standards of Service?

In the Revised FMR for Transco's Network Code Modification **0565 Transco Proposal for Revision of Network Code Standards of Service** at the following location:
<http://www.gasgovernance.co.uk/sites/default/files/0565.zip>

Impact on Transporters	
Area of Transporters' business	Potential impact
System operation	<p>The modification facilitates the realisation of CAPEX savings to the industry, anticipated to be approximately £9M, which is in-line with NGT's RIIO submission.</p> <p>Scotia Gas Networks note that DNOs will face ongoing costs (which would not have been incurred should the duplicate telemetry be installed) in maintaining and configuring the SCADA to SCADA link. Although this cost to DNs should not outweigh the economic benefit to the industry as a whole of the duplicate telemetry not being fitted, it will reduce the £9M saving to industry.</p>
Development, capital and operating costs	Reduction in development and CAPEX costs.
Recovery of costs	Reduction in development costs.
Price regulation	None
Contractual risks	None
Legislative, regulatory and contractual obligations and relationships	None
Standards of service	None

Impact on Code Administration	
Area of Code Administration	Potential impact
Modification Rules	None
UNC Committees	None
General administration	None

Impact on Code	
Code section	Potential impact

Impact on Code	
Offtakes Arrangements Document, Section E 2.3.5	As described in Section 3 of this document.

Impact on UNC Related Documents and Other Referenced Documents	
Related Document	Potential impact
Network Entry Agreement (TPD I1.3)	None
Network Exit Agreement (Including Connected System Exit Points) (TPD J1.5.4)	None
Storage Connection Agreement (TPD R1.3.1)	None
UK Link Manual (TPD U1.4)	None
Network Code Operations Reporting Manual (TPD V12)	None
Network Code Validation Rules (TPD V12)	None
ECQ Methodology (TPD V12)	None
Measurement Error Notification Guidelines (TPD V12)	None
Energy Balancing Credit Rules (TPD X2.1)	None
Uniform Network Code Standards of Service (Various)	None

Impact on Core Industry Documents and other documents	
Document	Potential impact
Safety Case or other document under Gas Safety (Management) Regulations	None
Gas Transporter Licence	None

Other Impacts	
Item impacted	Potential impact
Security of Supply	
Operation of the Total System	
Industry fragmentation	

Terminal operators, consumers, connected system operators, suppliers, producers and other non code parties	
--	--

6 Implementation

In September 2011 the Modification Panel determined this modification should follow self-governance procedures.

As self-governance procedures are proposed, implementation could be 16 business days after a Modification Panel decision to implement.

7 The Case for Change

In addition to those above, the Workgroup identified the following:

Advantages

The modification promotes the economic operation of pipe-lines at the Offtake from NGT's network to the DNOs' networks by relieving the requirement to always install NTS duplicate telemetry equipment and thereby reducing costs.

Disadvantages

None identified.

8 Legal Text

Legal Text

National Grid NTS provided the following legal text in response to a formal request from the UNC Modification Panel:

OAD Section E

Amend paragraph 2.3.5 to read as follows:

2.3.5 Where the NTS Telemetry Facilities in respect of an Offtake are NTS Electronic Telemetry Facilities, and the equipment (other than Telemetry Connection Facilities) provided by the DNO and utilised by such NTS Electronic Telemetry Facilities for the sending and receiving of signals to and from the Measurement Equipment and/or the National Grid NTS Connection Facilities ("**Equipment**") reaches the end of its service life, then National Grid ~~may~~ shall install NTS Physical Telemetry Facilities at the Offtake and connect such facilities (via the Telemetry Connection Facilities) to the Measurement Equipment. For the avoidance of doubt, the provisions of paragraph 2.3 shall apply to such NTS Physical Telemetry Facilities.

The equipment referred to above (the "**Equipment**") will be deemed to have reached the end of its service life on the earliest of the following:

- (a) the date on which a Reasonable and Prudent Operator would choose to routinely replace the Equipment having regard to its age and condition; or
- (b) the date on which the Equipment fails and is beyond economic repair; or
- (c) on such date as otherwise agreed between National Grid NTS and the DNO, such agreement not being unreasonably withheld.

9 Consultation Responses

Representations were received from the following parties:

Respondent	
Company/Organisation Name	Support Implementation or not?
National Grid Distribution	Support
National Grid NTS	Support
Northern Gas Networks	Support
Scotia Gas Networks	Support
Wales & West Utilities	Support

Of the five representations received, implementation was unanimously supported.

Summary Comments

All respondents note that the UNC obligates NTS to install its own duplicate Telemetry Facilities, at an NTS to DNO Offtake, when the existing DNO equipment reaches the end of its service life. Duplicating facilities at these Offtakes as a matter of course does not make financial sense and the removal of this mandatory requirement was a recommendation of the Enduring Distribution Network Arrangements project team.

Both National Grid Distribution and Wales & West Utilities note that there may be occasions in the future where the information provided by the DNO does not match the requirements of NTS and, in those instances, NTS may be required to fit their own equipment.

10 Panel Discussions

The Panel Chair summarised that the UNC obliges National Grid NTS to install telemetry equipment at all DN offtakes when the existing equipment reaches the end of its life. There is therefore an expectation that duplicate telemetry equipment will be installed in future.

Modification 0400S removes the obligation on National Grid NTS to install telemetry equipment. By avoiding the need to invest in unnecessary equipment, implementation of the modification would reduce the cost of system operation. Members noted that this would be consistent with economic and efficient system operation, and with promotion of efficiency in the implementation and administration of the Code.

Members then voted and determined unanimously that Modification 0400S be implemented.

11 Recommendations

Panel Recommendation

Having considered Modification Report 0400S, the Panel determines:

- that proposed Self-Governance Modification 0400S be made.