

**SECOND AMENDMENT AND RESTATEMENT AGREEMENT**

IN RESPECT OF THE

CONNECTED SYSTEMS AGREEMENT

(~~UK~~GB - IRELAND INTERCONNECTOR)

between

~~TRANSCO~~NATIONAL GRID GAS PLC

and

BGE (UK) LIMITED

Contents

1	DEFINITIONS AND INTERPRETATION	1
2	AMENDMENT AND RESTATEMENT	1
3	MISCELLANEOUS	<del>4</del> <u>2</u>
4	<del>RTPA</del>	<del>2</del>
<del>5</del>	GOVERNING LAW	2
	Schedule 1 - Form of Amended and Restated Connected Systems Agreement	3

THIS SECOND AMENDMENT AND RESTATEMENT AGREEMENT is made on ~~16<sup>th</sup> December~~  
~~2004~~<sup>\*\*</sup>                     

**BETWEEN:**

- (1) **Transeo National Grid Gas plc** (Company number 2006000) whose registered office is at 1-3 Strand, London WC2N 5EH ("**TranseoNGG**"); and
- (2) **BGE (UK) LIMITED** (Company number 02827969) whose registered office is at 10 Upper Bank Street, London E14 5JJ and who also has an office at Brighthouse Bay, Kirkcudbright, Scotland ("**BGE**").

**WHEREAS:**

A The Parties entered into a connected systems agreement on 25 August 1998 (the "**Connected Systems Agreement**") in relation to the Connected System Exit Point referred to therein.

B [By an Amendment and Restatement Agreement made on 16 December 2004 the Parties amended and restated the Connected Systems Agreement.](#)

C ~~B~~ By this Agreement the Parties wish further to amend and restate the terms of the Connected Systems Agreement.

**IT IS AGREED** that:

**1 DEFINITIONS AND INTERPRETATION**

1.1 In this Agreement, unless the context otherwise requires:

"**Amendment Effective Date**" means the date hereof; and

"**Amended and Restated Connected Systems Agreement**" means the Connected Systems Agreement as amended and restated in the form set out in Schedule 1 to this Agreement.

1.2 Capitalised terms defined in the Amended and Restated Connected Systems Agreement have the same meanings in this Agreement unless otherwise stated.

1.3 The headings in and to this Agreement are inserted for convenience only and shall not affect construction or interpretation.

**2 AMENDMENT AND RESTATEMENT**

2.1 On and from the Amendment Effective Date, the Connected Systems Agreement will be amended and restated in the form set out in Schedule 1.

2.2 This Agreement is supplemental to the Connected Systems Agreement and, except insofar as amended or supplemented by this Agreement, the Connected Systems Agreement will remain in full force and effect.

2.3 References in the Connected Systems Agreement to "this Agreement", "hereof", "hereunder" and expressions of similar nature shall be deemed to be references to the Connected Systems Agreement as amended and restated by this Agreement.

### 3 MISCELLANEOUS

3.1 The provisions of clauses 14.4 (notices) and 46~~15~~ (third parties) of the Amended and Restated Connected Systems Agreement shall apply to this Agreement as if set out in this Agreement, but as if references in those clauses to the Connected Systems Agreement were references to this Agreement.

### ~~4 RTPA~~

~~4.1 Any provision contained in this Agreement or in any arrangement of which this Agreement forms part by virtue of which the Restrictive Trade Practices Act 1976 ("the RTPA"), had it not been repealed, would apply to this Agreement or such arrangement shall not come into effect:~~

~~(a) if a copy of the Agreement is not provided to the Gas and Electricity Markets Authority ("the Authority") within 28 days of the date on which the Agreement is made; or~~

~~(b) if, within 28 days of the provision of the copy, the Authority gives notice in writing, to the party providing it, that it does not approve the Agreement because it does not satisfy the criterion specified in paragraphs 1(6) or 2(3) of the Schedule to The Restrictive Trade Practices (Gas Conveyance and Storage) Order 1996 ("the Order") as appropriate,~~

~~provided that if the Authority does not so approve the Agreement then clause 4.3 shall apply.~~

~~4.2 If the Authority does so approve this Agreement in accordance with the terms of the Order (whether such approval is actual or deemed by effluxion of time) any provision contained in this Agreement or in any arrangement of which this Agreement forms part by virtue of which the RTPA, had it not been repealed, would apply to this Agreement or such arrangement shall come into full force and effect on the date of such approval.~~

~~4.3 If the Authority does not approve this Agreement in accordance with the terms of the Order the parties agree to use their best endeavours to discuss with the Authority any provision (or provisions) contained in this Agreement by virtue of which the RTPA, had it not been repealed, would apply to this Agreement or any arrangement of which this Agreement forms part with a view to modifying such provision (or provisions) as may be necessary to ensure that the Authority would not exercise its right to give notice pursuant to paragraph 1(5)(d)(ii) or 2(2)(b)(ii) of the Schedule to the Order in respect of the Agreement as amended. Such modification having been made, the parties shall provide a copy of the Agreement as modified to the Authority pursuant to Clause 4.1 above for approval in accordance with the terms of the Order.~~

~~4.4 For the purposes of this clause 4, "Agreement" includes a variation of or an amendment to an agreement to which any provision of paragraphs 1(1) to (4) in the Schedule to the Order applies.~~

### 4 ~~5~~ GOVERNING LAW

This Agreement is governed by and shall be construed in accordance with English law.

**IN WITNESS** whereof this Agreement has been entered into on the date first specified above.

SIGNED by

for and on behalf of ~~Transeo~~ National Grid Gas plc

)  
)

)

**SIGNED** by )  
 )  
for and on behalf of **BGE (UK) Limited** )

# Schedule1 - Form of Amended and Restated Connected Systems Agreement

AMENDED AND RESTATED

CONNECTED SYSTEMS AGREEMENT

(UKGB - IRELAND INTERCONNECTOR)

BETWEEN

TRANSCONATIONAL GRID GAS PLC

AND

BGE (UK) LIMITED

**THIS AGREEMENT** dated 25 August 1998<sup>1</sup> is made

**BETWEEN:**

- (1) **Transco plc** (Company No. 2006000), (formerly called BG plc) having its registered office at: 1-3 Strand, London WC2N 5EH (hereinafter called "**TransecoNKG**")<sup>2</sup>
- and
- (2) **BGE (UK) LIMITED** (Company No. 02827969) having its registered office at 10 Upper Bank Street, London E14 5JJ and who also has an office at Brighthouse Bay, Kirkcudbright, Scotland (hereinafter called "**BGE**")

**WHEREAS:**

- A **TransecoNKG** is the operator of a pipeline system in Great Britain and holds a licence as a gas transporter under the Gas Act 1986, as amended, pursuant to which **TransecoNKG** has prepared a Network Code (a copy of which as in force at the date of this Agreement has been provided to BGE and as amended from time to time is available to BGE) setting out the terms on which shippers may arrange with **TransecoNKG** for the conveyance of gas by means of the **TransecoNKG** System.
- B BGE is the operator of the interconnector system comprising two sub-sea pipelines which are connected to the **TransecoNKG** System at Moffat via an onshore pipeline; and BGE or, pursuant to arrangements between them, its Affiliate has entered into one or more agreements for the transportation of gas by means of the BGE System from Moffat.
- C For the purposes of the Network Code the **CSEP Systems Connection Point** at which the BGE System is connected to the **TransecoNKG** System constitutes respectively a Connected System Exit Point and (in accordance with Annex F) a System Entry Point in relation to which BGE will be respectively the Connected System Operator and the Delivery Facility Operator.
- A The Network Code contemplates that:
- ~~A The Network Code contemplates that (1)~~ in relation to a Connected System Exit Point, a CSEP Network Exit Agreement will be entered into between **TransecoNKG** and the Connected System Operator for the purposes of providing for the application of certain provisions of the Network Code and setting out certain other matters in relation to the offtake of gas by **TransecoNKG** Shippers from the **TransecoNKG** System at the CSEP;
- (2) in relation to a System Entry Point, a Network Entry Agreement will be entered into between NKG and the Delivery Facility Operator containing Network Entry Provisions.
- B The Code of Operations contemplates that an agreement will be entered into between BGE and **TransecoNKG** in relation to the **CSEP Systems Connection Point** (as referred to in the Code of Operations as a 'Connected Systems Point').
- C This Agreement is the CSEP Network Exit Agreement relating to the CSEP and the Network Entry Agreement relating to the System Entry Point for the purposes of the Network Code and is the agreement contemplated by the Code of Operations.

---

<sup>1</sup> Amended and restated on the date of the Amendment and Restatement Agreement to which this Agreement is Schedule.

<sup>2</sup> Amended and restated on the date of the Amendment and Restatement Agreement to which this Agreement is Schedule.

- D ~~Transeo~~NGG has entered into ~~a CSEP~~the Moffat Ancillary Agreement ~~of even~~(as amended and restated on the same date ~~with~~as this Agreement) with those persons who at that date are ~~Transeo~~NGG Shippers.
- E The Parties have entered into a Pressure Maintenance Agreement of even date with this Agreement whereby the Parties have agreed certain pressure conditions which are to apply at CSPX and CSPY. The Pressure Maintenance Agreement does not apply to CSPZ.
- F Except as provided in Annex B-2, the Parties have agreed that the aggregate Exit Flow Rate (as defined in Annex B-2) on any Gas Flow Day shall not exceed 12038 MW Variable for the aggregate of CSPX and CSPY and shall not exceed 18057 MW Variable for the CSEP.
- G There is to be no physical flow of gas from the BGE System to the NGG System at the Systems Connection Point; and accordingly NGG Shippers and BGE Shippers may nominate and be allocated gas as delivered to the NGG System and] offtaken from the BGE System only to the extent that there are (in aggregate) nominations and allocations of equal or greater quantities as delivered to the BGE System and offtaken from the NGG System.
- H The Parties may from time to time agree to amend this Agreement in accordance with the terms hereof.

## IT IS HEREBY AGREED AS FOLLOWS:

### 1 DEFINITIONS

- 1.1 In this Agreement the following terms shall have the following meanings:

**"Affiliate"**: any subsidiary or holding company or any other subsidiary of any such holding company, for which purposes **"subsidiary"** and **"holding company"** shall have the meanings assigned to them under section 736 of the Companies Act 1985, as amended by section 144 of the Companies Act 1989;

**"Agreement"**: this Connected Systems Agreement;

**"Authority"**: the Gas and Electricity Markets Authority;

**"BGE Facilities"**: the facilities installed, owned and operated by BGE at the ~~CSEP~~Systems Connection Point, as described in Annex A2;

**"BGE Shipper"**: any person (whether or not being a ~~Transeo~~NGG Shipper) with which BGE or its Affiliate may for the time being have arranged for the transportation of gas in the BGE System or any part thereof, and including the gas trading division of BGE;

**"BGE System"**: the interconnector pipeline system operated by BGE or its Affiliate for the conveyance of gas ~~from downstream of the TranseoNGG System at Moffat to pipeline systems in the Republic of Ireland and (by way of a pipe connected to the BGE System) in Northern Ireland;~~ including the BGE Facilities;

**"Business Day"**: a day which is not a Saturday or Sunday and which is not a public or bank holiday in either England or the Republic of Ireland;

**"CER"**: the Commission for Energy Regulation;

**"Code of Operations"**: means the code of practice for the operation of the BGE System which governs certain aspects of the relationship between BGE or its Affiliate and BGE Shippers;

**"Competent Authority"**: any local; national or supra-national agency, authority, department, inspectorate, minister, official, court, tribunal or public or statutory person (whether autonomous or not) of the United Kingdom, the Republic of Ireland or the Isle of Man or the



European Union which has jurisdiction over [TranseoNGG](#) or BGE or the subject matter of this Agreement (including without limitation the Authority and the CER);

**"Connection Facilities"**: the [TranseoNGG](#) Facilities and the BGE Facilities;

**"Connected Systems Point"** or "CSP": CSPX, CSPY and/ or CSPZ, being the point or points (each being an Individual System ~~Exit~~ Point) at which the BGE System is connected to the [TranseoNGG](#) System as described in Annex A3;

**"CSEP"**: the [Systems Connection Point as](#) Connected System Exit Point for the purposes of the Network Code, ~~comprising the three CSPs;~~

**"CSEP Ancillary Agreement"**: ~~the agreement referred to in Recital G, as from time to time amended;~~

**"CSP"**: each of CSPX, CSPY and/or CSPZ as appropriate;

**"CSPX"**: the Individual System ~~Exit~~ Point marked as CSPX in Annex A3 (and where the context requires, such point as Individual System Exit Point);

**"CSPY"**: the Individual System Point marked as CSPY in Annex A3 (and where the context requires, such point as Individual System Exit Point);

~~"CSPY": the Individual System Exit Point marked as CSPY Annex~~ **"CSPZ"**: the Individual System ~~Exit~~ Point marked as CSPZ in Annex A3 (and where the context requires, such point as Individual System Exit Point);

**"Directive"**: any present or future directive, regulation request, requirement, instruction, code of practice, direction or rule of any Competent Authority having the force of law or if not having the force of law, if it is reasonable in all the circumstances for it to be treated as though it had legal force, or with which a party is otherwise required to comply and any modification, extension or replacement thereof;

~~**"Director"**: the Director General of Gas Supply in Great Britain;~~

**"Effective Date"**: shall have the meaning ascribed to in clause 2.1 of this Agreement;

**"Force Majeure Event"**: shall have the meaning ascribed to in clause 13.2 of this Agreement;

**"Legal Requirement"**: any act of parliament, regulation, licence or Directive of a Competent Authority;

~~**"Moffat Ancillary Agreement"**: the agreement referred to in Recital G, as from time to time amended;~~

**"Network Code"**: the Network Code prepared by [TranseoNGG](#) as from time to time modified pursuant to the licence referred to in Recital A;

**"NGG Facilities"**: the facilities installed, owned and operated by NGG at the Systems Connections Point, as described in Annex A1;

**"NGG Shipper"**: any gas shipper which is pursuant to the Network Code for the time being a CSEP User in respect of the CSEP;

**"NGG System"**: the main pipeline system operated by NGG in Great Britain (being the System as defined in the Network Code), including the NGG Facilities;

**"Operator"**: [TranseoNGG](#) or BGE;

**"Party"**: a party to this Agreement, which term for the avoidance of doubt shall be construed to include a party's successors in title and permitted assignees (and **"Parties"** shall mean both parties to this Agreement);

**"Pressure Maintenance Agreement"**: the agreement referred to in Recital H, as from time to time amended;

**"Reasonable and Prudent Operator"**: a person acting, in good faith, to perform its contractual obligations and, in so doing and in the general conduct of its undertaking, exercising that degree of skill, diligence, prudence and foresight which would reasonably and ordinarily be expected from a skilled and experienced operator engaged in the same type of undertaking under the same or similar circumstances;

**"Shipper"**: ~~a NGG Shipper or a BGE Shipper;~~

~~"Shipper": a Transco Shipper or a BGE Shipper;~~ **"System"**: the ~~Transco~~NGG System or the BGE System;

~~"Transco Facilities": the facilities installed, owned and operated by Transco at the CSEP, as described in Annex A1;~~

~~"Transco Shipper": any gas shipper which is pursuant to the Network Code for the time being a CSEP User in respect of the CSEP;~~

~~"Transco System": the main pipeline system operated by Transco in Great Britain (being the System as defined in the Network Code), including the Transco Facilities; and~~

**"System Entry Point" or "SEP"**: the Systems Connection Point as 'System Entry Point' (subject to Annex E, paragraph 2.2) for the purposes of the Network Code;

**"Systems Connection Point"**: the Connected Systems Points collectively; and

**"Transportation Arrangement"**: an arrangement made by ~~Transco~~NGG (constituting a transportation arrangement as defined in the licence referred to in Recital A) with a ~~Transco~~NGG Shipper, or by BGE or its Affiliate with a BGE Shipper, for the transportation of gas in such Operator's System to or from the ~~CSEP~~System Connections Point; and a reference to a Transportation Arrangement shall include the Network Code and the ~~CSEP~~Moffat Ancillary Agreement in the case of ~~Transco~~NGG and the Code of Operations in the case of BGE.

- 1.2 The provisions of Annex D as to the interpretation of technical expressions shall apply.
- 1.3 Words and expressions defined in the Network Code and not defined in this Agreement have the meanings ascribed to them from time to time under the Network Code.
- 1.4 References to Annexes and clauses are references to Annexes and clauses of this Agreement and, unless the context otherwise requires, references to Sections are to Sections of the Transportation Principal Document of the Uniform Network Code incorporated into the Network Code.
- 1.5 Unless otherwise provided, references to paragraphs are references to paragraphs of the Annex to this Agreement in which such reference is made.
- 1.6 The headings in and to this Agreement (including its Annexes) and in and to the clauses and paragraphs thereof are inserted for convenience only and shall not affect construction or interpretation.
- 1.7 In this Agreement, unless the context otherwise requires, references to the offtake of gas from the NGG System at the CSEP or any CSP to the BGE System are to the physical offtake of gas (representing the actual flow at the Systems Connection Point);

## 2 CONDITIONS AND DURATION

- 2.1 This Agreement shall be effective from 1 October 1998<sup>2 3</sup> (the "**Effective Date**") and (subject to earlier termination in accordance with this Agreement) shall continue in force until and unless terminated pursuant to clause 2.2 or 2.4.
- 2.2 If at any time following the first anniversary of the Effective Date no gas has been offtaken (for transportation by the BGE System) from the [TranseoNGG](#) System at one or more of the CSPs for a continuous period of 12 months (other than as a result of damage to or failure of any part of the [TranseoNGG](#) System or [TranseoNGG](#) Facilities or BGE System or BGE Facilities, where such damage is being remedied with reasonable diligence, and other than as a result of a Force Majeure Event), and it is not reasonably foreseeable that within the following 12 months such offtakes will take place, and as a result it is no longer economic for one or both Operators to maintain the connection of its System to the other Operator's System at the relevant CSP(s), the Operators shall discuss in good faith such circumstances and what steps may be taken with a view to agreeing upon a basis on which such continued connection may be made economic or upon the disconnection of such CSP(s) or upon the termination of this Agreement.
- 2.3 Upon the termination of this Agreement, unless the Operators have agreed that this Agreement is to be replaced by a further agreement relating to the same subject matter as this Agreement, the BGE System shall cease to be connected to the [TranseoNGG](#) System and each Operator shall be responsible at its cost for any required decommissioning, disassembly or removal of its Connection Facilities.
- 2.4 The Operators shall have the option to terminate this Agreement at any time by mutual consent. Such termination shall be without prejudice to the claims of either Operator in respect of any breach of this Agreement prior to termination.

## 3 GENERAL

- 3.1 Subject to the terms of this Agreement it is agreed that BGE shall be entitled to have the BGE System connected to the [TranseoNGG](#) System at the CSPs.
- 3.2 Without prejudice to any other agreement between the Parties, nothing in this Agreement shall:
- (a) impose or confer on either Operator any obligation to or entitlement against the other Operator to deliver gas to or offtake gas from the other Operator's System, or as to the rates, quantities, pressure and quality of gas so delivered or offtaken, (it being acknowledged that the only persons having such obligations or entitlements are BGE Shippers [in respect of the BGE system](#) and [TranseoNGG](#) Shippers [in respect of the NGG System](#));
  - (b) make any provision of any Transportation Arrangement of either [TranseoNGG](#) or BGE binding as between [TranseoNGG](#) and BGE;
  - (c) impose or confer on any [TranseoNGG](#) Shipper or BGE Shipper any obligation or entitlement to deliver gas to or offtake gas from the [TranseoNGG System or the BGE System](#) (but without prejudice to any Transportation Arrangement); or
  - (d) (without prejudice to the generality of sub-clause (a) above and other provisions of this Agreement) impose or confer on [TranseoNGG or BGE](#) any obligation to deliver gas to any particular CSP<sup>2 3</sup>;

---

<sup>2 3</sup> Amended and restated on the date of the Amendment and Restatement Agreement to which this Agreement is a Schedule.

(e) [Impose on any NGG Shipper or BGE Shipper any right or entitlement as against BGE or NGG.](#)

- 3.3 This Agreement shall not require either Operator to reinforce any part of its System or to take any other step with a view to its being feasible to accept the delivery of gas into, or make gas available for offtake from, its System at any CSP in any quantities or at any rate, nor to accept an application by any [TranseoNGG](#) Shipper or BGE Shipper for any particular NTS Exit Capacity or capacity to deliver gas into the BGE [System or the NGG](#) System.
- 3.4 Without prejudice to any other agreement between the Parties, neither Operator (the "first" Operator) shall be liable to the other in respect of any failure by (in the case of [TranseoNGG](#)) [TranseoNGG](#) Shippers and (in the case of BGE) BGE Shippers to comply with any provision of the first Operator's Transportation Arrangements, nor for any failure of the first Operator to make gas (at any rate or pressure or of any quality or in any quantity) available for offtake from or accept delivery of gas into its System.
- 3.5 Each Operator acknowledges that the other Operator's Transportation Arrangements contain or may contain provisions pursuant to which the delivery or offtake of gas to or from that Operator's System by (in the case of [TranseoNGG](#)) [TranseoNGG](#) Shippers and (in the case of BGE) BGE Shippers may be suspended or discontinued and/or the rate of such delivery or offtake may be limited.
- 3.6 Save as expressly provided otherwise in this Agreement, each Operator will perform its duties under this Agreement in accordance with the standard of a Reasonable and Prudent Operator and in compliance with the terms and conditions of this Agreement and agreed procedures.

#### **4 [EXIT AND ENTRY PROVISIONS](#)**

- 4.1 The provisions of Annex B are hereby given effect in relation to the CSEP.
- 4.2 The provisions of Annex C are hereby given effect for the purposes of the monitoring and measurement of the pressure, quantity and quality of gas flowing from the [TranseoNGG](#) System to the BGE System at the CSEP and the individual CSPs.

[4.3 \[The provisions of Annex F are hereby given effect in relation to the System Entry Point.\]\(#\)](#)

#### **5 CHANGE**

- 5.1 This Agreement shall not be amended except by agreement of [TranseoNGG](#) and BGE.
- 5.2 BGE acknowledges that pursuant to the Network Code, [TranseoNGG](#) will not amend any provision of this Agreement which governs or otherwise is directly relevant to the arrangements between [TranseoNGG](#) and its shippers pursuant to the Network Code except (i) with the approval of all [TranseoNGG](#) Shippers or (ii) upon [TranseoNGG](#)'s application, with the Authority's Condition 9(3) Approval, or (iii) in order to comply with any Legal Requirement.
- 5.3 Where any modification of the Network Code is made as a result of which any provision of this Agreement (insofar as the purpose of such provision is to supplement the Transportation Arrangements between [TranseoNGG](#) and [TranseoNGG](#) Shippers) is inconsistent with the Network Code or does not enable [TranseoNGG](#) to comply with the Network Code, [TranseoNGG](#) may, subject to BGE's prior written consent (such consent not to be unreasonably withheld or delayed), require that the relevant provision shall be amended so as to be so consistent or enable such compliance; but subject thereto and to clause 5.4, this Agreement shall remain in full force and effect notwithstanding any modification of the Network Code.
- 5.4 Without prejudice to clause 5.3, it is acknowledged that any provision of the Network Code which is or (as a result of a Code Modification) comes to be in conflict with any provision of

this Agreement will, as between [TransecoNKG](#) and [TransecoNKG](#) Shippers, prevail over such provisions of this Agreement.

- 5.5 [TransecoNKG](#) acknowledges that pursuant to the Code of Operations, BGE will not amend any provision of this Agreement which governs or otherwise is directly relevant to the arrangements between BGE and the BGE Shippers pursuant to the Code of Operations except after consultation with BGE Shippers.
- 5.6 Where any modification of the Code of Operations is made as a result of which any provision of this Agreement (insofar as the purpose of such provision is to supplement the Transportation Arrangements between BGE and BGE Shippers) is inconsistent with the Code of Operations or does not enable BGE to comply with the Code of Operations, BGE may, subject to [TransecoNKG](#)'s prior written consent (such consent not to be unreasonably withheld or delayed), require that the relevant provision shall be amended so as to be so consistent or enable such compliance; but subject thereto and to clause 5.7, this Agreement shall remain in full force and effect notwithstanding any modification of the Code of Operations.
- 5.7 Without prejudice to clause 5.6, it is acknowledged that any provision of the Code of Operations which is or comes to be in conflict with any provision of this Agreement will, as between BGE and BGE Shippers, prevail over such provisions of this Agreement.

## **6 CONNECTION FACILITIES**

- 6.1 BGE and [TransecoNKG](#) agree to consult and cooperate with a view to ensuring that the objective in clause 6.2 is satisfied.
- 6.2 The objective is that, without prejudice to clause 3.2, in all material respects the [TransecoNKG](#) Facilities and the BGE Facilities are and will continue to be technically and operationally compatible, as facilities by which the [TransecoNKG](#) System and the BGE System may safely be connected.
- 6.3 Where, by reason of any modification, other than a modification made to comply with any Legal Requirement, made or to be made by [TransecoNKG](#) to the [TransecoNKG](#) Facilities or by BGE to the BGE Facilities, the objective in clause 6.2 ceases or will cease to be satisfied, such Operator shall reimburse to the other any material expenditure reasonably incurred by the other for the purposes of ensuring that the objective continues to be or is again satisfied.
- 6.4 Each Operator shall be entitled, upon reasonable notice to the other, to inspect the other's Connection Facilities (and to have access to the site thereof accordingly), for the purposes of determining whether the objective in clause 6.2 is satisfied.
- 6.5 Without prejudice to any other agreement between [TransecoNKG](#) and BGE in respect of the installation of the [TransecoNKG](#) Facilities or the BGE Facilities, subject to the provisions of this clause 6, nothing in this Agreement shall impose any obligations upon either Operator or take effect as a warranty by either Operator in relation to its System; and neither Operator will be liable to the other in respect of any failure or malfunction thereof.

## **7 LIABILITY**

- 7.1 Each Operator (the "first" Operator) shall itself bear the risk of any loss, damage or liability which the first Operator may suffer, in consequence of its System being connected at the CSPs to the other Operator's System, as a result of anything done or not done (whether negligently or otherwise) by the other Operator, and the first Operator accordingly waives any liability (in contract, tort or otherwise) of the other Operator in respect of any such loss, damage or liability of the first Operator.

7.2 Without prejudice to any other provision of this Agreement excluding or limiting the liability of either Operator to the other (including, without limitation, the provisions of clause 7.1), neither Operator (the "first" Operator) shall be liable to the other Operator for:

- (a) any claim for loss, damage and/or expense of a third party; or
- (b) any indirect or consequential loss, damage, cost or financial harm; or
- (c) any loss of profit, loss of revenue, loss of use, loss of contract, loss of goodwill, or increased cost of working,

of whatever kind and nature suffered by the other Operator under or in connection with this Agreement, howsoever caused (including the default or negligence of the first Operator or a breach of any duty owed at law by the first Operator).

7.3 Nothing in this clause 7 shall exclude the liability of either Operator in respect of death or personal injury caused by that Operator's negligence.

## **8 INFORMATION AND CONFIDENTIALITY**

8.1 BGE and ~~Transeco~~NGG may disclose the terms of this Agreement to BGE Shippers or ~~Transeco~~NGG Shippers (or in either case a person who intends to become a BGE Shipper or ~~Transeco~~NGG Shipper) respectively, and to any Competent Authority.

8.2 BGE and ~~Transeco~~NGG may disclose any information obtained from the other pursuant to this Agreement:

- (a) respectively to any BGE Shipper and any ~~Transeco~~NGG Shipper and to any agent of any such BGE Shipper or ~~Transeco~~NGG Shipper, in each case to the extent contemplated by this Agreement or so far as required for the purposes of or in order to comply with their respective Transportation Arrangements; and
- (b) respectively to the CER and to the Authority.

8.3 Subject to clauses 8.2 and 8.4, each Operator shall keep confidential and shall not disclose any information relating to the affairs of the other which it obtains pursuant to this Agreement, other than information which is in the public domain or which it also obtains (other than under a duty of confidence) other than pursuant to this Agreement and save to the extent to which it is required to disclose such information by any Legal Requirement.

8.4 Each Operator shall jointly own all data obtained from measurement or monitoring equipment specified in Annex A and may (as respects the other Operator):

- (a) use such information in connection with the operation of its System, UK Link (or any successor thereto), the BGE Gas Transportation Management System (GTMS) (or any successor thereto), and for the purposes contemplated by this Agreement; and
- (b) disclose such information in accordance with clause 8.2.

8.5 Subject to clause 11 and to the operating procedures set out in Annex E and save as provided in Annex B, nothing in this Agreement shall require ~~Transeco~~NGG or BGE to act upon or in accordance with any instruction or information received from the other (but without prejudice to anything contained in the Act).

8.6 This clause 8 is without prejudice to the provisions of any Transportation Agreement as to confidentiality as between BGE and BGE Shippers or (as the case may be) ~~Transeco~~NGG and ~~Transeco~~NGG Shippers.

## **9 OPERATING PROCEDURES**

- 9.1 The operating procedures for giving effect to the provisions of this Agreement are as set out in Annex E (as the same may be amended from time to time in accordance with the provisions thereof).
- 9.2 Such procedures shall be binding on the Operators, unless they expressly provide that they are not to be binding; but in the event of any conflict between any such procedures and any other provision of this Agreement, such other provision of this Agreement shall prevail.

## **10 MAINTENANCE**

- 10.1 Without prejudice to clause 8.5 and to paragraph 4.3 of Annex B-1, the Operators agree to exchange information as to, and to take reasonable steps to co-ordinate, their respective plans for maintenance of their respective Connection Facilities and adjacent parts of the BGE System or [TranseoNKG](#) System.
- 10.2 Where the operation of any pipeline inspection or maintenance equipment in either System requires a specific even rate of offtake of gas from or delivery of gas to the other System at any of the CSPs for any period, each Operator agrees to co-operate with the other (and with each BGE Shipper and/or [TranseoNKG](#) Shipper as appropriate) with a view to ensuring that such rate of offtake is maintained for such period.

## **11 EMERGENCIES**

- 11.1 Each Operator agrees to provide reasonable co-operation to the other with a view to ensuring safety in the event of any emergency circumstances affecting the other's System, provided that (without prejudice to any right of the affected Operator to take any action itself in such event) this shall not require either Operator to act in breach, in the case of BGE, of any Transportation Arrangement of BGE and, in the case of [TranseoNKG](#), any Transportation Arrangement of [TranseoNKG](#).
- 11.2 The operating procedures set out in Annex E include procedures for giving effect to clause 11.1.
- 11.3 Without prejudice to any other right of [TranseoNKG](#) to reduce or discontinue the flow of gas at the CSEP or at any CSP, if, as a result of emergency circumstances affecting the [TranseoNKG](#) System or any part of that System which includes the CSEP or any CSP, it is necessary for [TranseoNKG](#) to take steps to reduce the level of firm demand on the [NKG](#) System or such part of it, [TranseoNKG](#) may require that the rate at which gas is being offtaken from the CSEP or any CSP is reduced:
- (a) consistently with any Directive of a Competent Authority relating to such reduction; or
  - (b) in the absence of any such Directive, by a proportionate amount commensurate with the proportionate reduction in demand required in aggregate at points (other than the CSEP) on the System or such part of it, in each case determined after all demand of an interruptible nature has been interrupted.

## **12 EXPERT**

- 12.1 Wherever this Agreement provides or the Parties agree that any matter is to be referred to an Expert for determination the provisions of this clause 12 shall apply.
- 12.2 A Party seeking the referral of such matter to an Expert shall give notice to the other Party that it wishes an Expert to be appointed and with such notice shall give:

- (a) details of the matter which it proposes shall be resolved by the Expert; and
  - (b) the proposed terms of reference.
- 12.3 If within twenty-one (21) days from the service of the said notice the Parties have failed to agree upon the identity of the Expert and/or the terms of reference then the matter may be referred by either Party to the President of the Energy Institute who shall be requested to select the Expert in accordance with this clause and if willing to do so settle the terms of reference of such Expert within thirty (30) days.
- 12.4 Upon an Expert being agreed or selected under the foregoing provisions of this clause either Party shall forthwith notify such Expert of his selection and of the proposed terms of his appointment and shall request him within fourteen (14) days to confirm to the Parties whether or not he is willing and able to accept the appointment on the terms proposed.
- 12.5 If the Expert shall be either unwilling or unable to accept the appointment or shall not have confirmed his willingness and ability to accept such appointment within such period then (unless the Parties are able to agree on the appointment of another Expert) the matter may be referred by either Party to the President of the Energy Institute who shall be requested to make a further selection and the process shall be repeated until an Expert is found who accepts the appointment in accordance with the proposed terms.
- 12.6 No person shall be appointed to act as the Expert under this Agreement:
- (a) who at the time of his appointment is a director, office holder or employee of or directly or indirectly retained as a consultant to either of the Parties or an Affiliate of any of them;
  - (b) unless he/ she shall have the relevant experience and/or training to determine the matter in dispute in accordance with the terms of reference.
- 12.7 The Expert shall be deemed not to be an arbitrator but shall render his determination as an expert and the provisions of the Arbitration Act 1996 (as amended from time to time) and the law relating to arbitration shall not apply to such Expert or his determination or the procedure by which he reaches his determination.
- 12.8 The determination of the Expert shall be final and binding upon the Parties save in the event of fraud or manifest error.
- 12.9 Each of the Parties shall bear its own costs of providing all data, information and submissions given by it and the costs and expenses of all the counsel, witnesses and employees retained by it but the costs and expenses of the Expert and any independent advisors to the Expert and any costs of his appointment shall be borne equally by the Parties.
- 12.10 Any and all communications between either Party and the Expert shall be made in writing and a copy thereof provided simultaneously to the other and no meeting between the Expert and either Party shall take place unless both Parties have a reasonable opportunity to attend any such meeting.

### **13 FORCE MAJEURE**

- 13.1 For the avoidance of doubt, the provisions of this Agreement shall be without prejudice to any question as to whether:
- (a) either Operator is entitled, as a result of circumstances constituting force majeure for the purposes of its Transportation Arrangements, to any relief in respect of its obligations (or liability in respect of its obligations) pursuant to such Transportation Arrangements; or



- (b) either Operator is entitled, as a result of circumstances constituting force majeure for the purposes of the Pressure Maintenance Agreement or any other agreement between them, to any relief in respect of its obligations (or liability in respect of its obligations) under any such agreement.

13.2 For the purposes of this Agreement, a "**Force Majeure Event**" shall mean any event or circumstance or combination of events or circumstances which is beyond the reasonable control of an Operator and which, or the effect of which, adversely affects the performance by that Operator of its obligations under or pursuant to this Agreement provided, however, that any such event or circumstance, or combination of events or circumstances, shall not constitute a Force Majeure Event hereunder if it could have been prevented, overcome, or remedied by the affected Operator through the exercise of reasonable diligence and reasonable care. Force Majeure Events hereunder shall include (without limitation) each of the following events and circumstances, but only to the extent that each satisfies the above requirements:

- (a) any act of war (whether declared or undeclared), hostilities, invasion, armed conflict or act of foreign enemy, blockade, embargo, mobilisation, requisition, revolution, riot, insurrection, civil commotion or disorder, act of terrorism, or sabotage;
- (b) act of God;
- (c) radioactive contamination, ionising radiation or contamination by radioactivity from any nuclear fuel, or from any nuclear waste from the combustion of nuclear fuel, radioactive toxic explosive, or other hazardous properties;
- (d) strikes, works to rule or go-slows;
- (e) earthquake, tidal wave, flood, storm, cyclone, typhoon, tornado, lightning, landslip or landslide or adverse weather or climatic conditions;
- (f) fire or explosion;
- (g) epidemic or plague;
- (h) unlawful, illegal, criminal or negligent acts of third parties;
- (i) any event or circumstances of a nature analogous to the foregoing.

13.3

- (a) If, by reason of a Force Majeure Event, an Operator is wholly or partially unable to carry out its obligations under this Agreement, the affected Operator shall give the other Operator notice of the Force Majeure Event as soon as practicable, describing the Force Majeure Event and the obligations affected together with an estimate of the period of time that the affected Operator will be unable to perform the obligations and any other relevant matters.
- (b) Failure by the affected Operator to give notice of a Force Majeure Event to the other Operator as required by clause 13.3(a) shall not prevent the affected Operator from giving such notice at a later time; provided however, that in such case, the affected Operator shall not be excused pursuant to clause 13.5 from any failure or delay in complying with its obligations under or pursuant to this Agreement until the notice required by clause 13.3(a) has been given.

13.4 The affected Operator shall use all reasonable efforts to mitigate the effects of a Force Majeure Event, including, but not limited to, the payments of all sums of money which are reasonable and cost effective in the light of the likely efficacy of the mitigation measures. This clause 13.4 shall not oblige the affected Operator to settle any labour dispute.

- 13.5 So long as the affected Operator has at all times since the occurrence of the Force Majeure Event complied with its obligations under clause 13.4 and continues so to comply, then:
- (a) the affected Operator shall not be liable for any failure or delay in performing its obligations (other than the obligation on the part of either Operator to make any payments to the other Operator under or pursuant to this Agreement) to the extent that such failure or delay has been caused or contributed to by the Force Majeure Event or its effects; and
  - (b) the time limits and deadlines for the performance by the affected Operator of its obligations under this Agreement (other than the obligation on the part of either Operator to make any payments to the other Operator under or pursuant to this Agreement) which are affected by such Force Majeure Event shall be extended Day to Day for so long as the relevant Force Majeure Event or its effects continue.

## 14 MISCELLANEOUS

- 14.1 Either Operator may assign this Agreement to any Affiliate of such Operator, and with the consent of the other Operator (which shall not unreasonably be withheld) to any other person, provided in each case that the assignee is capable of complying with the obligations of the assigning Operator and that the assignee shall enter into an agreement with the other Operator covenanting to be bound by the obligations of the assigning Operator under this Agreement as if the assignee had originally been named in this Agreement in place of the assigning Operator, whereupon the assigning Operator shall be released from all further obligations under this Agreement.
- 14.2 Neither Operator shall appoint any other person to operate its Connection Facilities without first informing and consulting with the other Operator as to such appointment and agreeing or procuring such other person to agree to such procedural and operational requirements as the other Operator may reasonably require in connection with such appointment.
- 14.3 This Agreement shall be governed by English law, ~~and (subject to clause 12 hereof) the English courts shall have exclusive jurisdiction in respect of this Agreement.~~
- 14.4 Where any notice or other communication (other than an operational communication given in accordance with the procedures referred to in clause 14.5) is to be given or made by either Operator to the other under this Agreement:
- (a) such communication shall be in writing and may be delivered to the recipient or sent by first class prepaid letter (airmail if sent overseas) or facsimile transmission to the address or facsimile transmission number of the recipient as set out in sub-clause (d) below or such other address or number as may be notified hereunder by that Operator from time to time for this purpose;
  - (b) such communication shall be deemed to have been given or made and delivered, if by post, on the second Business Day after posting (fifth Business Day after posting if sent by airmail), if by delivery, when left at the relevant address (or on the first Business Day thereafter if left on a non Business Day), and (subject to sub-clause (c)(ii) below) if by facsimile transmission between the hours of 09:00 and 17:00 on a Business Day, at the time of receipt by the sender of confirmation of complete transmission and otherwise on the first Business Day after transmission;
  - (c) where a communication by facsimile is received in an incomplete or illegible form:
    - (i) if the recipient so requests (by telephone or otherwise), the sender shall promptly retransmit the communication to the recipient; and
    - (ii) provided that the request for re-transmission was made no later than the first Business Day following the deemed day of receipt (in accordance with sub-

clause (b) above) of the first facsimile, the communication shall not be deemed to have been received until the time (being between 09:00 and 17:00 hours on a Business Day) of receipt by the sender of confirmation of such retransmission.

- (d) For the purposes of sub-clause (a) above:
- (i) notices and other communications to ~~Transco~~[NGG](#) (other than operational communications) shall be sent to:

~~Transco~~[NGG](#) plc  
NGT House  
Warwick Technology Park  
Gallows Hill  
Warwick  
CV34 6DA

Marked for the attention of: Commercial - Customer Agreements Manager

Facsimile Number: 01926 656605

- (ii) notices and other communications to BGE (other than operational communications) shall be sent to:

BGE (UK) Limited  
Brighthouse Bay  
Kirkcudbright  
Scotland

Marked for the attention of: the Company Secretary

Facsimile Number: 01557 870292

14.5 Procedures for giving operational communications are set out in Annex E.

## ~~15~~ ~~RTPA CLAUSE~~<sup>3</sup>

~~15.1~~ Any provision contained in this Agreement or in any arrangement of which this Agreement forms part by virtue of which this Agreement or such arrangement is subject to registration under the Restrictive Trade Practices Act 1976 shall not come into effect:

- ~~(a)~~ if a copy of the Agreement is not provided to the Director within 28 days of the date on which the Agreement is made; or
- ~~(b)~~ if, within 28 days of the provision of the copy, the Director gives notice in writing, to the party providing it, that she does not approve the Agreement because it does not satisfy the criterion specified in clause 1(6) of the Schedule to The Restrictive Trade Practices (Gas Conveyance and Storage) Order 1996

~~provided that if the Director does not so approve the Agreement then clause 15.2 shall apply.~~

~~15.2~~ Any provision contained in this Agreement or in any arrangement of which this Agreement forms part by virtue of which this Agreement or such arrangement is subject to registration under the Restrictive Trade Practices Act 1976 shall not come into effect until the day following the date on which particulars of this Agreement and of any such arrangement have

---

<sup>3</sup> This Clause 15 was relevant for this Agreement when first executed but is not relevant to registration of the Amendment and Restatement Agreement to which this is scheduled.

~~been furnished to the Office of Fair Trading under Section 24 of the Act (or on such later date as may be provided for in relation to any such provision) and the Parties hereto agree to furnish such particulars within three months of the date of this Agreement.~~

## 15     ~~16~~ **THIRD PARTIES**

The Contracts (Rights of Third Parties) Act 1999 shall not apply to this Agreement. A person who is not a Party (including any employee, officer, agent, representative or sub-contractor of either Party) shall have no right (whether under the Contracts (Rights of Third Parties) Act 1999 or otherwise) to enforce any term of this Agreement which expressly or by implication confers a benefit on that person, without the express prior agreement in writing of the Parties, which agreement must refer to this clause.

## 16     **JURISDICTION**

Subject to Clause 12, the parties irrevocably agree that the English courts have exclusive jurisdiction to settle any dispute arising out of or in connection with this Agreement. Each party agrees to waive any objection to the English courts, whether on the grounds of venue or that the forum is not appropriate.

## 17     **COUNTERPARTS**

The parties may execute this Agreement in any number of counterparts, each of which is an original. A set of counterparts, executed by all the parties, together forms one and the same instrument.

**IN WITNESS** whereof the duly authorised representatives of the Operators have executed this Agreement the day and year above written.

Signed for and on behalf of  
**Transco plc**

Signed for and on behalf of:  
**BGE (UK) Limited**

Signature:     N.R. SHAW

Signature:     PHIL CRONIN

Name:            N.R. SHAW

Name:            PHIL CRONIN

Position:        DIRECTOR, TRANSCO

Position:        DIRECTOR

**ANNEX A1 –**

**TRANSCO** NGG FACILITIES - Note: the reference in the diagram below to “TRANSCO” should be read as a reference to “NGG”

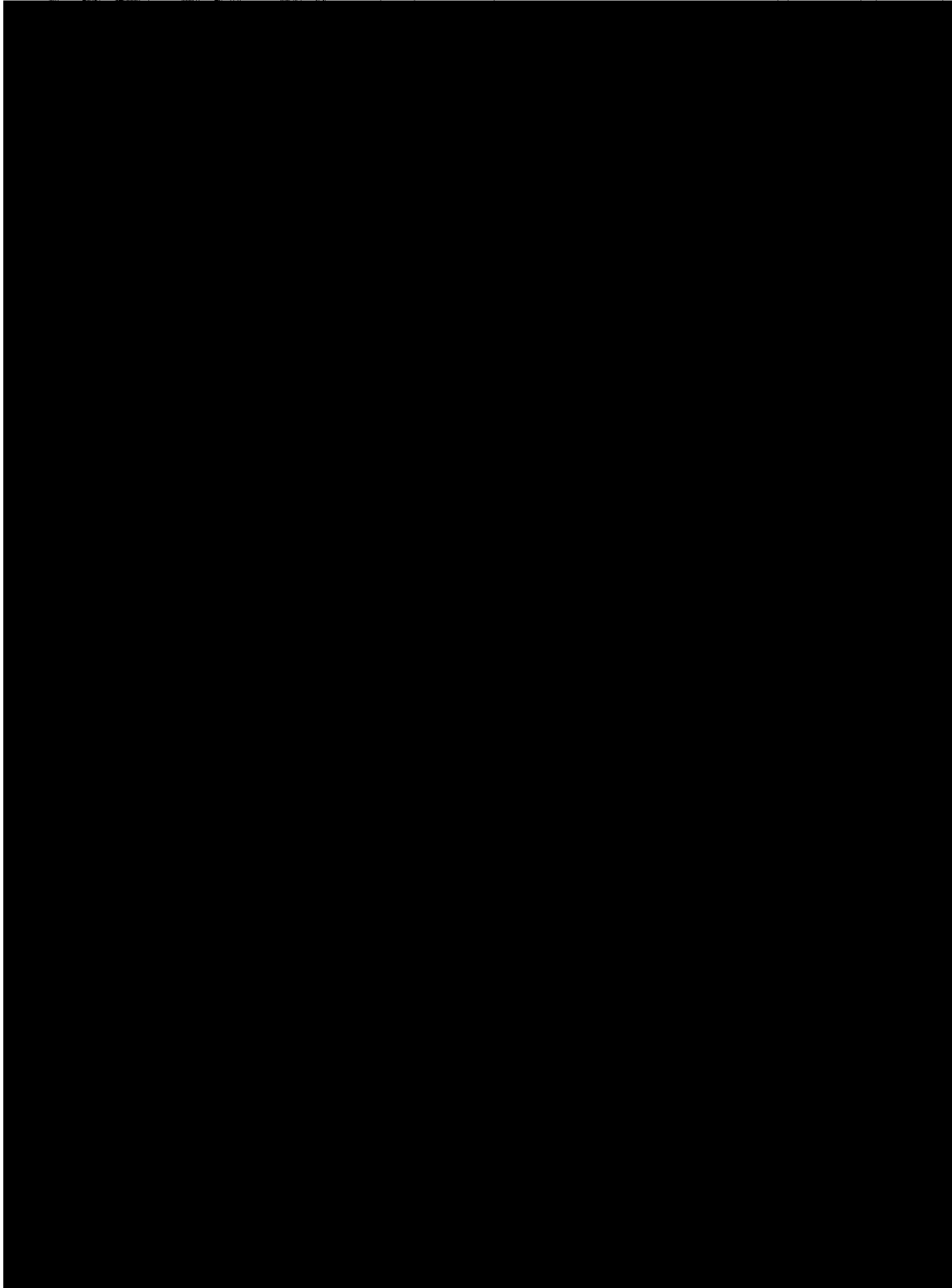



**ANNEX A2 - BGE FACILITIES**

ANNEX A2  
BGE FACILITIES

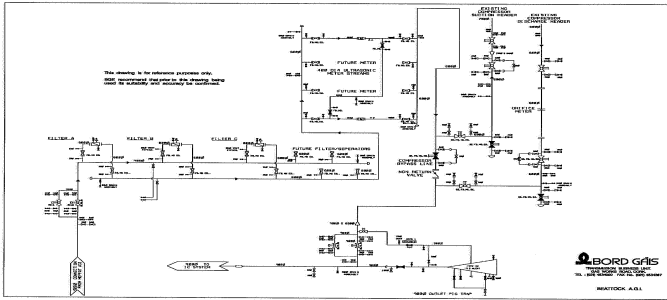



**ANNEX A3 - TRANSCONGG FACILITIES AND BGE FACILITIES (MARKING EACH CSP)**

Note: the reference in the diagram below to “TRANSCO” should be read as a reference to “NGG”

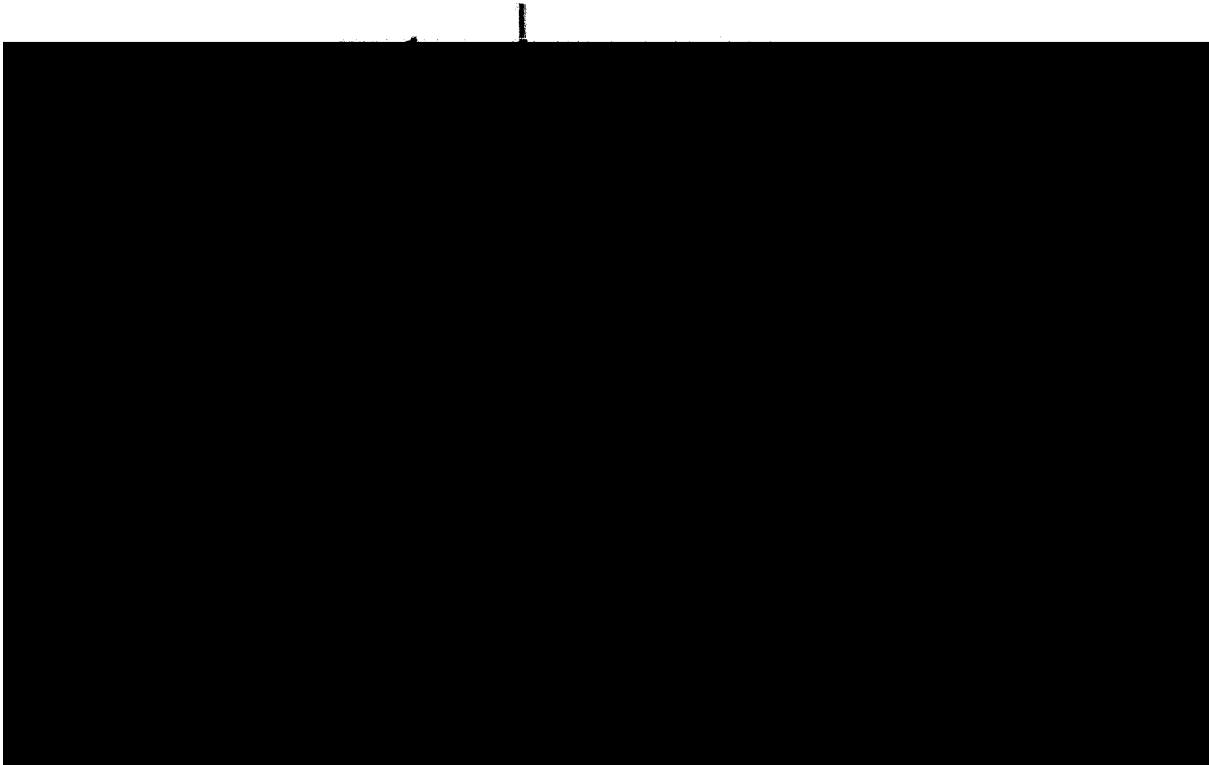

## **ANNEX B - CSEP PROVISIONS**

### Contents

- Annex B1: General and interpretation
- Annex B2: Flow profiles, rate changes, etc
- Annex B3: Downstream Capacity Register

## ANNEX B-1 - GENERAL AND INTERPRETATION

### 1 Scope

This Annex B sets out provisions applying in respect of the CSEP and the offtake of gas from the ~~Transeo~~NGG System for delivery to the BGE System.

### 2 Interpretation

- 2.1 Unless otherwise expressly provided, references in this Annex B to rates of offtake, ~~delivery~~ or flow of gas are to the instantaneous rate (expressed in MW or MCM/hour) of such offtake, ~~delivery~~ or flow from, ~~to~~ or in the ~~Transeo~~NGG System, and a reference to rate of offtake, is to such rate of offtake in aggregate by all ~~Transeo~~NGG Shippers, from the ~~Transeo~~NGG System at the CSEP.

### 3 ~~CSEP~~Moffat Ancillary Agreement

- 3.1 BGE acknowledges that it has received a copy of the ~~CSEP~~Moffat Ancillary Agreement; and ~~Transeo~~NGG agrees to provide a copy of any revision thereof promptly upon such revision being made.
- 3.2 It is acknowledged that (except as provided in paragraph 4) the provisions which would otherwise be contained in this Agreement (as the CSEP Network Exit Agreement) are contained in the ~~CSEP~~Moffat Ancillary Agreement pursuant to Section ~~J5.9.3 of the Network Code~~5.9.3.

### 4 Certain Network Exit Provisions

- 4.1 For the purposes of Section ~~J5.8.1~~4.3.1(a), the points of offtake at the CSEP comprise the points marked CSPX, CSPY and CSPZ respectively in Annex A3.
- 4.2 For the purposes of Sections ~~J5.8.1~~4.3.3(~~ba~~) and 4.3.3(~~dc~~):
- (a) the provisions of Annex C as to the measurement of flow (and determination of volume) and the determination of calorific value of gas offtaken shall apply;
  - (b) Annex C specifies or refers to the measurement equipment which is (and is required to be) installed at CSPX and CSPY, and at CSPZ.
- 4.3 For the purposes of Section ~~J5.8.2~~4.3.1 (~~af~~):
- (a) for the purposes of Section L4.3.2(a), there are no allowable Days of Programmed Maintenance in any Planned Maintenance Period (or in any three consecutive Planned Maintenance Periods);
  - (b) for the purposes of Section L4.4.1, where ~~Transeo~~NGG intends to undertake pipeline inspection which would require particular rates of offtake at the CSEP, it is a requirement that ~~Transeo~~NGG Shippers cooperate so far as is practicable with any reasonable requirement of ~~Transeo~~NGG as to the rate of offtake of gas from the ~~Transeo~~NGG System at the CSPs.
- 4.4 For the purposes of Section ~~Q3.4.3~~, the procedures set out in Annex E shall apply.

## 5 Gas Quality and Exit Pressure

### 5.1

- (a) The Applicable Offtake Pressure at CSPX and CSPY for the purposes of Section J2.1.4 ~~of the Network Code~~ shall (without prejudice to the provisions of Section J2.1.5) be the pressure determined pursuant to the provisions of the Pressure Maintenance Agreement.
- (b) The Pressure Maintenance Agreement shall not apply to CSPZ and the Applicable Offtake Pressure at CSPZ for the purposes of Section J2.1.4 ~~of the Network Code~~ shall (without prejudice to the provisions of Section J2.1.5) be 25 bar.
- (c) The anticipated normal offtake pressure for CSPZ is 47 bar gauge and [TranseoNKG](#) will notify BGE of any reductions thereto at the same time it so notifies the [TranseoNKG](#) Shippers in accordance with Section J2.2.2. For the avoidance of doubt the provision of such information shall not imply any liability to BGE in respect of the same.

5.2 If [TranseoNKG](#) becomes aware that the composition of gas which is being made or will be made available for offtake from the [TranseoNKG](#) System at the CSEP is not in compliance with the Standard Offtake Requirements (as defined in the Network Code), [TranseoNKG](#) will notify BGE as soon as possible after becoming so aware.

5.3 Where the composition of gas made available for offtake from the [TranseoNKG](#) System at the CSEP is for the time being not in compliance with the Standard Offtake Requirements, [TranseoNKG](#) shall, if requested by BGE, secure that the flow of gas at CSPY is discontinued as soon as is reasonably practicable after such request provided always that:

- (a) [TranseoNKG](#) has full control of all relevant flow control valves at the relevant time on the [TranseoNKG](#) System; and
- (b) BGE operates the BGE System to facilitate such flow discontinuance at CSPY and secures that the flow of gas at CSPX and CSPZ is discontinued.

## ANNEX B-2 - FLOW PROFILES, RATE CHANGES, ETC

### 1 General

- 1.1 The quantities in which and rates at which gas is offtaken from the ~~Transeo~~NGG System at the CSEP, and changes in such quantities and rates, shall be limited in accordance with this Annex B-2. Unless stated otherwise or the context otherwise requires, references in this Annex B-2 to quantities and rates of offtake shall be to those at the CSEP and not at any individual CSP(s).
- 1.2 Each Operator shall be entitled to take any operational step available to it to ensure that the requirements of this Annex B-2 are complied with in respect of the rate of offtake.
- ~~1.3 The Parties acknowledge that the provision of an Exit Flow Profile is the responsibility of Transeo Shippers (and accordingly Transeo will not accept such a profile other than one submitted by or on behalf of Transeo Shippers); and agree that:~~
- 1.3 Each Operator acknowledges that the Moffat Users and the BGE Shippers may, with the approval of the Operators appoint an Exit Flow Profile Agent pursuant to Clause 8.2 of the Moffat Ancillary Agreement to submit Exit Flow Profiles on their behalf. Each Operator agrees that it shall not and shall not be required to approve the appointment of any such proposed agent where:
- (a) such Operator is not reasonably satisfied as to the technical and operational ability of the proposed agents to submit Exit Flow Profiles in accordance with this Annex B2; and/or
- (b) the methodology by which the Agent shall develop such Exit Flow Profiles is not in a form which is acceptable to such Operator.
- 1.4 If and for so long as an Exit Flow Profile Agent has not been appointed pursuant to Clause 8.2 of the Moffat Ancillary Agreement and approved by the Operators in accordance with this Annex B2 or if the Exit Flow Profile Agent so appointed does not provide an Exit Profile Notice (and NGG informs BGE that the Exit Flow Profile Agent has not provided the Exit Flow Profile), BGE shall provide NGG with the notifications:
- (a) ~~Transeo is not obliged to secure that such profile is provided by Transeo Shippers; required by this Annex B-2 and for the purposes of Section J4.5;~~
- (b) ~~Transeo may agree (without any obligation or liability to BGE) to prepare and provide such a profile on behalf of Transeo Shippers by reference to their Output Nominations and Renominations; in accordance with a methodology which shall be published by BGE from time to time.~~
- (c) ~~where Transeo does so agree, Transeo will provide to BGE a copy of each profile and any revision thereof prepared by Transeo.~~
- 1.5 For the purposes of Section J4.5.1 and in respect of each Gas Flow Day, the End of Day Demand Forecast Notice (setting out the estimated total amount of gas to be offtaken during the Gas Flow Day) shall be provided by BGE to NGG no later than 12.00 hours on the Preceding Day.
- 1.6 ~~1.4~~To the extent that revisions in the Exit Flow Profile are made only by reason of a change in the quantities of gas which Shippers intend to be offtaken from the ~~Transeo~~NGG System at the CSEP on a Day, it is agreed that BGE will not require BGE Shippers and ~~Transeo~~NGG will not require ~~Transeo~~NGG Shippers to nominate (pursuant to Transportation Arrangements) rates or profiles, beyond what is commensurate with paragraph 6.1, of flow of gas at the CSEP.

1.7 ~~4.5~~ For the purposes of this Annex B-2:

- (a) "**Available Firm Flow Rate**" means the rate (in MW) calculated as 1/24 of the aggregate of the NTS Exit Capacity (in MW) for the time being held by ~~Transeo~~[NGG](#) Shippers at the Firm CSEP (in accordance with the ~~CSEP~~[Moffat](#) Ancillary Agreement);
- (b) "**Curtailed Notice**" is defined in paragraph 5.5;
- (c) "**Exit Flow Profile**" means a statement in the form in Appendix A, showing the quantity of gas (taking account of paragraph 7.3) to be offtaken, and the rate (for each hour) of offtake of gas, from the System during a Day at the CSEP (and, for information purposes only, showing an indication of the breakdown of such quantity between CSPX and CSPY, and CSPZ); and "**Initial Exit Flow Profile**" (which is also an Exit Flow Profile) is defined in paragraph 2.1;
- (d) "**Exit Flow Rate**" means the instantaneous rate of offtake of gas at the CSEP (being, for the avoidance of doubt, the aggregate of all three CSPs) (other than during a Ramp Period), shown or to be shown in an Exit Flow Profile, expressed in kWh;
- (e) "**Final Preceding Day Rate**" means the Prevailing Exit Flow Rate applying at the end of the Preceding Day, as shown in the Exit Flow Profile in force at the end of the Preceding Day;
- (f) "**Flexed**" is defined in paragraph 6.2;
- (g) "**Flow Rate Change Limit**" means the lesser of the Available Firm Flow Rate and 7,408 MW Variable;
- (h) "**Flow Rate Change Time**" means the time (being the start of the Ramp Period) with effect from which a revision in the Exit Flow Rate becomes effective;
- (i) "**Incremental Flow Rate**" is the amount by which, upon a revision of the Exit Flow Profile, the Exit Flow Rate is revised, calculated as:

$$\Delta Q/T$$

where:

$\Delta Q$  is the amount by which the aggregate quantity (in kWh) of gas shown in the Exit Flow Profile is revised by the revised Exit Flow Profile (and shall be positive in the case of an increase, and negative in the case of a decrease, in such quantity); and

T is the period in hours from the Flow Rate :Change Time to the end of the Gas Flow Day;

- (j) "**Initial Exit Flow Rate**" means the Exit Flow Rate applying at the start of the Gas Flow Day,
- (k) "**Prevailing Exit Flow Rate**" at any time means the Exit Flow Rate prevailing at or immediately before such time; and
- (l) in relation to any change (whether an increase or a decrease) in the Exit Flow Rate or Flexed Exit Flow Rate:
  - (i) "**Ramp Rate**" means the instantaneous rate of change (in MW/minute) of the rate of offtake; and
  - (ii) "**Ramp Period**" is the period of time over which (on the basis of the prevailing Ramp Rate permitted from time to time in paragraph 7.2) such change occurs.

1.8 ~~4.6~~ Where any provision of this Annex B-2 refers to any amount in "MW Variable" such amount has been derived from an amount in MCM at an assumed calorific value of 40 MJ/Cubic Metre; and where the average calorific value of gas offtaken from the ~~Transee~~NGG System at the CSEP differs materially from such assumed value the MW amount referred to in such provision shall be adjusted accordingly.

## 2 Exit Flow Profile

2.1 If:

(a) ~~2.1 And~~ and for so long as an Exit Flow Profile Agent has not been appointed pursuant to Clause 8.2 of the Moffat Ancillary Agreement an Exit Flow Profile (the "Initial Exit Flow Profile") in relation to the Gas Flow Day ~~is to~~will be provided ~~(by BGE to NGG by 17.00 hours on the Preceding Day; or on behalf of Transee Shippers) to Transee-~~not later than 17:00 hours on the Preceding Day.

(b) the Exit Flow Profile Agent so appointed does not provide an Exit Profile Notice to NGG by 17.00 hours on the Preceding Day (and NGG notifies BGE that the Exit Flow Profile Agent has not provided such Exit Flow Profile), an Exit Flow Profile (the "Initial Exit Flow Profile") in relation to the Gas Flow Day will be provided by BGE to NGG as soon as reasonably practicable following the receipt of NGG's notice by BGE.

2.2 After the Initial Exit Flow Profile has been provided (but subject to paragraph 2.3), and during the Gas Flow Day, a revised Exit Flow Profile may be provided to ~~Transee~~NGG, not less than 30 minutes before the Change Lead Time starts, showing a revised Exit Flow Rate with effect from a time (on the hour) not earlier than the expiry of the Change Lead Time (but no revision shall be shown in the Exit Flow Rate applying before that time).

2.3 A revised Exit Flow Profile provided before the Gas Flow Day shall not specify an Exit Flow Rate which does not comply with paragraph 4.1(a) unless a period equal to the minimum allowed Change Lead Time will have expired from the start of the Gas Flow Day before the Flow Rate Change Time.

2.4 Subject to paragraph 2.5, the "Change Lead Time" is a period of at least 2 hours before the Flow Rate Change Time (and it is acknowledged that the relative brevity of such minimum lead time reflects the relatively low minimum permitted Ramp Rate under paragraph 7.2).

2.5 If:

(a) ~~Transee~~NGG is requested ~~(by Transee Shippers or their~~by BGE (or where an Exit Flow Profile Agent is appointed pursuant to Clause 8.2 of the Moffat Ancillary Agreement, by such agent) to accept a revision of the Exit Flow Profile upon less notice than is required pursuant to paragraph 2.4; and

(b) ~~Transee~~NGG determines that it is feasible (in accordance with the Network Code), consistently with the expectation in Section J4.6-64.5.7 (construed mutatis mutandis), for ~~Transee~~NGG to make gas available for offtake in accordance with such revised profile,

~~then Transee Shippers may revise~~ the Exit Flow Profile may be revised in accordance with such request.

2.6 If, upon a request pursuant to paragraph 2.5(a), ~~Transee~~NGG determines (pursuant to paragraph 2.5(b)) that it is not feasible to make gas available for offtake in accordance with such request:

- (a) ~~Transeo~~NGG will, not later than the start of the Change Lead Time, reject the request by giving notice to BGE ~~and Transeo Shippers or their agent (if appointed); and~~(and where an Exit Flow Profile Agent is appointed pursuant to Clause 8.2 of the Moffat Ancillary Agreement, such agent); and
  - (b) such notice will (but without obliging ~~Transeo~~NGG to accept any further request) notify BGE ~~and Transeo Shippers or their agent (if appointed) whether in Transeo~~(and where an Exit Flow Profile Agent is appointed pursuant to Clause 8.2 of the Moffat Ancillary Agreement, such agent) whether in NGG's determination it would be feasible to make gas available at the Exit Flow Rate requested but upon notice other than that requested.
- 2.7 An Exit Flow Profile shall show, in relation to a change in the rate of offtake (at the start of the Day or within the Day) the Ramp Period and the change in rate on the basis of the permitted Ramp Rate in accordance with paragraph 7.2.
- 2.8 An Exit Flow Profile shall not specify an Exit Flow Rate or Flexed Exit Flow Rate which exceeds the maximum flow rate; for which purposes the maximum flow rate for the aggregate of CSPX and CSPY is 12,038 MW Variable and the maximum flow rate in respect of the CSEP is 18,057 MW Variable or (following any modification of the Connection Facilities) any greater rate(s) notified by ~~Transeo~~NGG to BGE and ~~Transeo~~NGG Shippers ~~or their agent (if appointed)~~ as the maximum rate of flow permitted by such facilities.
- 2.9 Subject to paragraphs 2.5 and 5.1, a statement which purports to be an Exit Flow Profile but which is not in the form in Appendix A or is not provided in accordance with the requirements of this Annex, or which provides for a rate of offtake (at any time of the Day) which is not in compliance with any requirement (including without limitation paragraph 2.7) of this Annex as to the Exit Flow Rate, will not be valid or take effect as an Exit Flow Profile; and where it receives such a statement ~~Transeo~~NGG will notify the person submitting such statement of such invalidity and where appropriate will advise of the reasons for such invalidity (which notification for the avoidance of doubt shall not be a Curtailment Notice).
- 2.10 Where an Exit Flow Profile has been submitted earlier than required under this Annex, a further Exit Flow Profile may be submitted (whether to correct any invalidity in accordance with paragraph 2.9 in the earlier profile or to reflect a change in circumstances), subject to and in accordance with this Annex, which will replace the earlier such Exit Flow Profile; provided that not more than two such replacement Exit Flow Profiles may be submitted in any hour (commencing on the hour).

### **3 Exit Flow Rate**

- 3.1 The Initial Exit Flow Rate shall be a uniform rate for the Day, calculated as 1/24 of the aggregate quantity shown in the Exit Flow Profile submitted pursuant to paragraph 2.1.
- 3.2 Upon any revision of the Exit Flow Profile which is effective after the start of the Gas Flow Day, the Exit Flow Rate applying with effect from the end of the Ramp Period (following the Flow Rate Change Time) shall be a uniform rate for the remainder of the Day, calculated as the sum of the Prevailing Exit Flow Rate and the Incremental Flow Rate.

### **4 Exit Flow Rate Limits**

- 4.1 Subject to paragraph 5.1, the Initial Exit Flow Rate and the Flexed Initial Exit Flow Rate shall not:
  - (a) differ from the Final Preceding Day Rate by more than the Flow Rate Change Limit; nor
  - (b) exceed the Available Firm Flow Rate.



- 4.2 Subject to paragraph 5.1, the Exit Flow Rate and the Flexed Exit Flow Rate upon any revision of the Exit Flow Profile shall not:
- (a) differ from the Initial Exit Flow Rate by more than the Flow Rate Change Limit; nor
  - (b) exceed the Available Firm Flow Rate; nor
  - (c) be less than zero.

## 5 Flow rate flexibility and curtailment

5.1 If:

- (a) ~~Transeo~~NGG is requested ~~(by Transeo Shippers or their agent)~~ by BGE or an Exit Flow Profile Agent is appointed pursuant to Clause 8.2 of the Moffat Ancillary Agreement to accept an Initial Exit Flow Profile, or a revision of the Exit Flow Profile, which does not comply:
  - (i) with the requirements of paragraph 4.1(a) or (as the case may be) 4.2(a); or
  - (ii) with the requirements of paragraph 4.1(b) or (as the case may be) 4.2(b); and
- (b) ~~Transeo~~NGG determines that it is feasible (in accordance with the Network Code), ~~consistently~~ consistent with the expectation in Section J ~~4.6.6~~ 4.5.7 (construed mutatis mutandis), for ~~Transeo~~NGG to make gas available for offtake in accordance with such profile or revised profile

then, subject to paragraph 5.3, an Initial Exit Flow Profile may be provided, or the Exit Flow Profile revised, in accordance with such request.

5.2 If, upon a request pursuant to paragraph 5.1(a), ~~Transeo~~NGG determines (pursuant to paragraph 5.1(b)) that it is not feasible to make gas available for offtake in accordance with such request:

- (a) ~~Transeo~~NGG will reject the request by giving a Curtailment Notice to BGE ~~and Transeo Shippers or their agent (if appointed);~~ (and where an Exit Flow Profile Agent is appointed pursuant to Clause 8.2 of the Moffat Ancillary Agreement, to such agent);
- (b) in the case of a requested revision, the Exit Flow Profile prevailing before such request shall continue in force.

5.3 Where an initial Exit Flow Profile has been provided or an Exit Flow Profile revised for an increased Exit Flow Rate or Flexed Exit Flow Rate pursuant to paragraph 5.1, and accepted by ~~Transeo~~NGG, ~~Transeo~~NGG may at any subsequent time, by giving a Curtailment Notice, require that the Exit Flow Profile be revised by reducing the Exit Flow Rate or Flexed Exit Flow Rate, with effect not later than a time (on the hour) specified by ~~Transeo~~NGG (the "**curtailment time**", being at the end of the relevant Ramp Period), and by an amount not less than the amount determined in accordance with paragraph 5.4.

5.4 The amount of the reduction specified by ~~Transeo~~NGG shall be such that the revised Exit Flow Rate or Flexed Exit Flow Rate would be not less than the greatest Exit Flow Rate or Flexed Exit Flow Rate which might have been specified in the Exit Flow Profile without infringing the requirements of paragraph 4.

5.5 For the purposes of this Annex B-2 a "**Curtailment Notice**" is a notice given by ~~Transeo to BGE and Transeo Shippers or their agent (if appointed)~~ NGG to BGE (and where an Exit Flow Profile Agent is appointed pursuant to Clause 8.2 of the Moffat Ancillary Agreement, to such agent):

- (a) of rejection of a request ~~purse;~~pursuant to paragraph 5.1(a)(i);
  - (b) of rejection of a request pursuant to paragraph 5.1(a)(ii);
  - (c) requiring revision pursuant to paragraph 5.3 of an Exit Flow Profile accepted pursuant to a request under paragraph 5.1(a)(i);
  - (d) requiring revision pursuant to paragraph 5.3 of an Exit Flow Profile accepted pursuant to a request under paragraph 5.1(a)(ii);
  - (e) requiring a reduction of the Exit Flow Rate and Flexed Exit Flow Rate (below the Available Firm Flow Rate) pursuant to clause 11.3.
- 5.6 The ~~CSEP~~Moffat Ancillary Agreement refers to Curtailment Notices under paragraph 5.5(b) and (d) as 'Interruption Notices' and makes further provision in respect of such notices.
- 5.7 A Curtailment Notice shall specify the subparagraph of paragraph 5.5 under which it is given.
- 5.8 A Curtailment Notice under paragraph 5.5(a) or (b) shall be given:
- (a) in connection with an Initial Exit Flow Profile, as early as reasonably practicable, but not later than 21:00 hours on the Preceding Day;
  - (b) in connection with a revised Exit Flow Profile, as early as reasonably practicable and not later than the start of the Change Lead Time.
- 5.9 A Curtailment Notice under paragraph 5.5(c) or (d):
- (a) shall be given:
    - (i) in the case of paragraph 5.5(c), not less than 5 hours before the curtailment time;
    - (ii) in the case of paragraph 5.5(d), not less than the relevant period before the curtailment time (where the relevant period is the same as the period of notice of any Interruption which ~~Transeo~~NGG is required to give under ~~Section G6.8.4~~Transition Document Part IIC Paragraph 5.8.1);
  - (b) shall specify the curtailment time, the reduced Exit Flow Rate required by such notice, and the estimated period (which shall not bind ~~Transeo~~NGG) for which such reduced Exit Flow Rate is required;
  - (c) shall not be given later than 21:00 hours on the Preceding Day, unless:
    - (i) ~~Transeo~~NGG has accepted a revised Exit Flow Profile, requested under paragraph 5.1(a), and submitted after 21:00 hours on the Preceding Day; and
    - (ii) the Curtailment Notice requires a reduction by reference to that revised Exit Flow Profile, but would not require a reduction by reference to the Initial Exit Flow Profile.
- 5.10 Where ~~Transeo~~NGG has given a Curtailment Notice under paragraph 5.5(c) or (d), as soon as reasonably practicable after ~~Transeo~~NGG determines that the requirement for the reduced Exit Flow Rate or Flexed Exit Flow Rate no longer applies or will at a certain time cease to apply, ~~Transeo~~NGG will so notify BGE and ~~Transeo~~NGG Shippers ~~or their agent (if appointed)~~(and where an Exit Flow Profile Agent is appointed pursuant to Clause 8.2 of the Moffat Ancillary Agreement, such agent), specifying the time (where later than the time of such notification) with effect from which such requirement will cease to apply.

- 5.11 There shall be no minimum period of notice required for a Curtailment Notice under paragraph 5.5(e); and an Initial Exit Flow Profile shall be provided or (as the case may be) the prevailing Exit Flow Profile shall be revised in compliance with any such Curtailment Notice, provided that the requirements of paragraphs 2.3, 4.1(a) and 4.2(a) shall not apply in respect of an Exit Flow Profile submitted in compliance with such a Curtailment Notice.
- 5.12 For the avoidance of doubt, the proportionate reduction (which may be required by a Curtailment Notice under paragraph 5.5(e)) referred to in clause 11.3 is a reduction below the Available Firm Flow Rate.

## **6 Profile flexibility**

- 6.1 An Exit Flow Profile may show, in addition to the Exit Flow Rate, a rate of offtake which deviates in any hour of the Day from the Exit Flow Rate by not more than 20% of the Prevailing Exit Flow Rate, provided that the aggregate quantity of gas shown in the Exit Flow Profile as being offtaken in the Day taking account of any such deviation is equal to the aggregate quantity which would be offtaken in the Day at the Exit Flow Rate.
- 6.2 For the purposes of this Agreement, a reference to the "**Flexed**" Exit Flow Rate or Incremental Flow Rate at any time is a reference to such Exit Flow Rate or incremental Flow Rate as adjusted by the amount (in MW) of any deviation at such time pursuant to paragraph 6.1 (and in the absence of any such deviation to the Exit Flow Rate or Incremental Flow Rate, without adjustment).

## **7 Rates of exit flows**

- 7.1 Subject to and consistently with paragraphs 7.2 and 7.4, and subject to clause 8.9 of the [GSEP Moffat](#) Ancillary Agreement, the parties intend and agree that the rate of offtake should be equal to the prevailing Flexed Exit Flow Rate.
- 7.2 Where a change in the rate of offtake is to be made (by reason of a revision in the Exit Flow Profile at the start of or during the Gas Flow Day), the Ramp Rate shall not exceed an instantaneous rate of change equal to the prevailing rate notified by ~~Transco to BGE and to Transco Shippers or their agent (if appointed~~ [NGG to BGE \(and where an Exit Flow Profile Agent is appointed pursuant to Clause 8.2 of the Moffat Ancillary Agreement, such agent\)](#); provided that:
- (a) such rate so notified shall not be less than (and until ~~Transee~~ [NGG](#) first gives such a notification, shall be equal to) 12.639 MW/minute;
- (b) where ~~Transee~~ [NGG](#) notifies a reduction in such prevailing rate and the prevailing Exit Flow Profile provides for a Ramp Period which (having regard to the time at which such reduction takes effect and the times at which such Ramp Period starts and commences) is inconsistent with such reduction, the Exit Flow Profile shall be revised accordingly.
- 7.3 A change in Exit Flow Rate pursuant to paragraph 7.2 shall not commence earlier than the start of the Gas Flow Day or (as the case may be) the relevant Flow Rate Change Time, and shall be assumed (for the purposes of paragraph 2.6) to occur at the greatest Ramp Rate permitted under paragraph 7.2.
- 7.4 For the avoidance of doubt, the Flexed Exit Flow Rate relates to the operation of the ~~Transee~~ [NGG](#) System but not the BGE System, and nothing in this Annex B-2 shall be construed as an undertaking by BGE that the BGE System will receive or will be capable of receiving gas at a rate equal to the Flexed Exit Flow Rate.
- 7.5 (Without prejudice to any other operational procedure established by the Operators) where BGE becomes aware that, as a result of any constraint or other circumstances affecting the

BGE System, the rate at which gas is being offtaken from the [TranseeNGG](#) System will or is likely to be less than the Prevailing Exit Flow Rate, BGE will so notify [TranseeNGG](#) of that fact; and BGE consents to [TranseeNGG](#) informing [TranseeNGG](#) Shippers of any such notice given by BGE.

**APPENDIX A - Form of Exit Flow Profile**

From: BGE (UK) Ltd. Fax No. 00 353 21 ~~353767~~[453 4373](tel:4534373)

Exit Flow Profile Moffat Offtake (MOFFO)

To: ~~Transeo~~[NGG](mailto:NGG) Fax No. 00 44 (0)870 191 0646  
National Control Centre  
Warwick

Re: Moffat gas flow information for gas day

		For information only	For information only
Time Hour commencing	Aggregate Offtake <del>Flowrate</del> <a href="#">Flow rate</a> at the CSEP (comprising CSPX, CSPY and CSPZ) (the "Exit Flow Rate")	<del>Aggregate Offtake-Flowrate at CSPX and CSPY</del>	<del>Offtake Flowrate at CSPZ</del>
0600	kWh	<del>kWh</del>	<del>kWh</del>
0700	kWh	<del>kWh</del>	<del>kWh</del>
0800	kWh	<del>kWh</del>	<del>kWh</del>
0900	kWh	<del>kWh</del>	<del>kWh</del>
1000	KWh	<del>KWh</del>	<del>kWh</del>
1100	kWh	<del>kWh</del>	<del>kWh</del>
1200	kWh	<del>kWh</del>	<del>kWh</del>
1300	kWh	<del>kWh</del>	<del>kWh</del>
1400	kWh	<del>kWh</del>	<del>kWh</del>
1500	kWh	<del>kWh</del>	<del>kWh</del>
1600	kWh	<del>kWh</del>	<del>kWh</del>
1700	kWh	<del>kWh</del>	<del>kWh</del>
1800	kWh	<del>kWh</del>	<del>kWh</del>
1900	kWh	<del>kWh</del>	<del>kWh</del>
2000	kWh	<del>kWh</del>	<del>kWh</del>
2100	kWh	<del>kWh</del>	<del>kWh</del>
2200	kWh	<del>kWh</del>	<del>kWh</del>
2300	kWh	<del>kWh</del>	<del>KWh</del>



## ANNEX B-3 - DOWNSTREAM CAPACITY REGISTER

- 1 This Annex B-3 applies for the purposes of enabling [TranseoNKG](#) to implement the provisions of Schedule 3 to the [CSEP Moffat](#) Ancillary Agreement referred to in Recital G, which govern the basis on which [TranseoNKG](#) Shippers may apply for and hold NTS Exit Capacity at the CSEP.
- 2 For the purposes of this Annex B-3:
  - (a) **"Downstream Capacity Holder"** means a person which is for the time being recognised by BGE as being entitled, on a firm (and not interruptible) basis, to have gas conveyed in the BGE System;
  - (b) **"Downstream Capacity Entitlement"** means, at any time, in relation to the following period of 12 months (or any greater period for which such entitlement may exist), the maximum quantity (in kWh/Day) of gas which a Downstream Capacity Holder is entitled, on a firm (and not interruptible) basis, to have conveyed in the BGE System on the Day in such period on which the greatest aggregate quantity of gas may be conveyed in such system;
  - (c) **"Downstream Capacity Register"** means a statement prepared by BGE setting out the identity of each person which is a Downstream Capacity Holder, and for each such person its Downstream Capacity Entitlement.
- 3 BGE shall provide to [TranseoNKG](#) a Downstream Capacity Register upon signature of this Agreement.
- 4 Whenever any change occurs in the identity of the Downstream Capacity Holders or their Downstream Capacity Entitlements, BGE shall not less than 5 Business Days before such change is effective provide to [TranseoNKG](#) a revised Downstream Capacity Register.
- 5 The Downstream Capacity Register shall be provided to [TranseoNKG](#) in such paper and/or electronic formats as BGE and [TranseoNKG](#) shall agree.
- 6 [TranseoNKG](#) shall keep BGE informed of the levels of NTS Exit Capacity at the CSEP from time to time held by [TranseoNKG](#) Shippers.
- 7 [TranseoNKG](#) shall keep the Downstream Capacity Register confidential and in particular shall not disclose it to [TranseoNKG](#) Shippers; and BGE shall keep the details provided under paragraph 6 confidential and in particular shall not disclose them to BGE Shippers.

## ANNEX C - MEASUREMENT PROVISIONS

### Part 1 CSP Metering

#### 1 Definitions

In this Annex:

**"BGE Equipment"** means the equipment installed and operated by BGE as shown in Annex A2 that is necessary to enable BGE to determine the calorific value of gas and to convert the volume of gas measured by the BGE Meters into energy (in kWh);

**"BGE Meters"** means the meters and equipment that have been installed and are operated by BGE for measuring volumes of gas in MCM at CSPZ as shown in Annex A2.

**"BGE Permitted Range"** means the percentage range of Uncertainty in relation to energy flow and volume flow that applies to the BGE Supply Point Measurement Equipment as specified in Table 2 in Part 3 of this Annex C;

**"BGE Supply Point Measurement Equipment"** means the BGE Equipment and the BGE Meters;

**"Constant Systematic Error"** has the meaning given to it in BS ISO TR 5168:1998;

**"Supply Point Measurement Equipment"** means the BGE Supply Point Measurement Equipment and/or the [TranseoNKG](#) Supply Point Measurement Equipment as appropriate;

**"[TranseoNKG](#) Equipment"** means the equipment installed and operated by [TranseoNKG](#) as shown in Annex A1 that is necessary to enable [TranseoNKG](#) to determine the calorific value of gas and to convert the volume of gas measured by the [TranseoNKG](#) Meters into energy (in kWh);

**"[TranseoNKG](#) Meters"** means the meters and equipment that have been installed and are operated by [TranseoNKG](#) for measuring volumes of gas in MCM at CSPX and CSPY, as shown in Annex A1;

**"[TranseoNKG](#) Permitted Range"** means the percentage range of Uncertainty in relation to energy flow and volume flow that applies to the [TranseoNKG](#) Supply Point Measurement Equipment as specified in Table 1 in Part 3 of this Annex C;

**"[TranseoNKG](#) Supply Point Measurement Equipment"** means the [TranseoNKG](#) Equipment and the [TranseoNKG](#) Meters;

**"Uncertainty"** has the meaning given to it in BS ISO TR 5168:1998; and

**"Variable Systematic Error"** has the meaning given to it in BS ISO TR 5168:1998.

#### 2 General

##### 2.1

- (a) The quantity of gas offtaken from the [TranseoNKG](#) System at CSPX and CSPY shall be determined by the [TranseoNKG](#) Supply Point Measurement Equipment.
- (b) The quantity of gas offtaken from the [TranseoNKG](#) System at CSPZ shall be determined by the BGE Supply Point Measurement Equipment.



- (c) The quantity of gas offtaken from the [TranseoNKG](#) System at the CSEP shall be the aggregate of that offtaken at CSPX and CSPY and at CSPZ.

## 2.2

- (a) [TranseoNKG](#) shall be responsible for installing, calibrating, operating, maintaining, repairing and validating the [TranseoNKG](#) Supply Point Measurement Equipment.
- (b) BGE shall be responsible for installing, calibrating, operating, maintaining, repairing and validating the BGE Supply Point Measurement Equipment.

## 3 Uncertainty and Error

### 3.1

- (a) In all flow conditions at CSPX and CSPY:
  - (i) the total Uncertainty in the measurements of the volume flow rates and energy flow rates of the [TranseoNKG](#) Supply Point Measurement Equipment shall, at all flow rates from 6% to 100% of the Maximum Daily Flow Rate (as defined in Part 3 of this Annex C), be within the [TranseoNKG](#) Permitted Range; and
  - (ii) the [TranseoNKG](#) Supply Point Measurement Equipment shall be free of Constant Systematic Error and Variable Systematic Error in respect of both volume flow rates and energy flow rates.
- (b) In all flow conditions at CSPZ:
  - (i) the total Uncertainty in the measurements of the volume flow rates and energy flow rates of the BGE Supply Point Measurement Equipment shall, at all flow rates from 6% to 100% of the Maximum Daily Flow Rate (as defined in Part 3 of this Annex C), be within the BGE Permitted Range; and
  - (ii) the BGE Supply Point Measurement Equipment shall be free of Constant Systematic Error and Variable Systematic Error in respect of both volume flow rates and energy flow rates.

### 3.2

- (a) The methods specified in BS EN ISO 5167-1:1997 and BS ISO TR 5168:1998 shall be used for the calculation of Uncertainty in the measurement of volume flow rates and for the calculation of Constant Systematic Errors and Variable Systematic Errors in volume flow rates in each case in respect of the [TranseoNKG](#) Meters and as referred to in paragraph 3.1(a).
- (b) The methods specified in BS7965:2000 and BS ISO TR 5168:1998 shall be used for the calculation of Uncertainty in the measurement of volume flow rates and for the calculation of Constant Systematic Errors and Variable Systematic Errors in volume flow rates in each case in respect of the BGE Meters and as referred to paragraph 3.1(b).
- (c) The methods specified in BS EN ISO 5167-1:1997 and BS ISO TR 5168:1998 shall be used for the calculation of Uncertainty in the measurement of energy flow rates and for the calculation of Constant Systematic Errors and Variable Systematic Errors in energy flow rates in each case in respect of the [TranseoNKG](#) Equipment and as referred to in paragraph 3.1(a).
- (d) The methods specified in BS EN ISO 5167-1:1997 and BS ISO TR 5168:1998 shall be used for the calculation of Uncertainty in the measurement of energy flow rates and for

the calculation of Constant Systematic Errors and Variable Systematic Errors in energy flow rates in each case in respect of the BGE Equipment and as referred to in paragraph 3.1(b).

## 4 Validation

### 4.1

- (a) The methods specified in the approved validation procedures agreed between [TranseoNCG](#) and BGE and as more particularly set out in BS EN ISO 5167-1:1997 and in the document entitled "Procedure for Validation of Equipment Associated with Measurement Systems for the Calculation of Mass Volume and Energy [FlowrateFlow rate](#) of Gas (Within Scope)" dated March 2001 (Reference T/PR/ME2) Parts 1 and 2, as may be amended from time to time by agreement between [TranseoNCG](#) and BGE, shall be used for the validation of the [TranseoNCG](#) Supply Point Measurement Equipment.
- (b) The methods specified in the approved validation procedures agreed between [TranseoNCG](#) and BGE and as more particularly set out in BS EN ISO 5167-1:1997 and in BS7965:2000, shall be used for the validation of the BGE Supply Point Measurement Equipment.

### 4.2

- (a) BGE may request that the [TranseoNCG](#) Supply Point Measurement Equipment be validated at any time in which case any such validation shall be carried out as soon as reasonably practicable. Subject to paragraph 4.3, the costs and expenses of such validation, and of any adjustment or replacement of the components of the [TranseoNCG](#) Supply Point Measurement Equipment made as a result of any validation made pursuant to this paragraph 4.2(a) shall, if the [TranseoNCG](#) Supply Point Measurement Equipment is found both to read within the [TranseoNCG](#) Permitted Range and to not be subject to any Constant Systematic Error or Variable Systematic Error, be paid by BGE and, in any other case, by [TranseoNCG](#).
- (b) [TranseoNCG](#) may request that the BGE Supply Point Measurement Equipment be validated at any time in which case any such validation shall be carried out as soon as reasonably practicable. Subject to paragraph 4.3, the costs and expenses of such validation, and of any adjustment or replacement of the components of the BGE Supply Point Measurement Equipment made as a result of any validation made pursuant to this paragraph 4.2(b) shall, if the BGE Supply Point Measurement Equipment is found both to read within the BGE Permitted Range and to not be subject to any Constant Systematic Error or Variable Systematic Error, be paid by [TranseoNCG](#) and, in any other case, by BGE.

4.3 Either Party may request that the Supply Point Measurement Equipment installed and operated by the other Party be validated if the previous validation took place more than one (1) month previously and any validation pursuant to this paragraph 4.3 shall be carried out as soon as reasonably practicable. [TranseoNCG](#) shall bear the costs and expenses of the validation of the [TranseoNCG](#) Supply Point Measurement Equipment, and of any adjustment or replacement of the components of the [TranseoNCG](#) Supply Point Measurement Equipment made as a result thereof. BGE shall bear the costs and expenses of the validation of the BGE Supply Point Measurement Equipment, and of any adjustment or replacement of the components of the BGE Supply Point Measurement Equipment made as a result thereof.

4.4 Subject to paragraph 4.7:

- (a) [TranseoNCG](#) may at its own expense undertake validation of the [TranseoNCG](#) Supply Point Measurement Equipment and may adjust or replace the components of the

[TranseoNCG](#) Supply Point Measurement Equipment also at its own expense at any time; and

- (b) BGE may at its own expense undertake validation of the BGE Supply Point Measurement Equipment and may adjust or replace the components of the BGE Supply Point Measurement Equipment also at its own expense at any time.

4.5 Immediately following validation pursuant to paragraph 4.2, 4.3 or 4.4, the individual components of the respective Supply Point Measurement Equipment shall be adjusted or replaced by [TranseoNCG](#) (in the case of the [TranseoNCG](#) Supply Point Measurement Equipment) and BGE (in the case of the BGE Supply Point Measurement Equipment) as necessary so that the relevant Supply Point Measurement Equipment complies with the provisions of paragraph 3.1 above.

4.6

- (a) Where the [TranseoNCG](#) Supply Point Measurement Equipment is found when validated to be subject to either a Constant Systematic Error or a Variable Systematic Error in respect of volume flow and/ or energy flow, irrespective of whether the [TranseoNCG](#) Supply Point Measurement Equipment is found to read within or outside the [TranseoNCG](#) Permitted Range, then:

- (i) the [TranseoNCG](#) Supply Point Measurement Equipment shall be assumed to have been subject to the Constant Systematic Error or Variable Systematic Error (as appropriate) during the latter half of the period since last validated and found to be within the [TranseoNCG](#) Permitted Range and not to be subject to either a Constant Systematic Error or a Variable Systematic Error or, if later, since last adjusted to correct a previous Constant Systematic Error or Variable Systematic Error or to read within the [TranseoNCG](#) Permitted Range (except in the case where it is proved that the [TranseoNCG](#) Supply Point Measurement Equipment has been subject to a Constant Systematic Error or Variable Systematic Error (as appropriate) since some other date in which case the error shall be assumed to have applied since such date);
- (ii) for the purposes of paragraph 4.6(b), the quantities read as offtaken from the [TranseoNCG](#) System on each Day at CSPX and CSPY during the period when the [TranseoNCG](#) Supply Point Measurement Equipment is assumed to have been subject to a Constant Systematic Error or Variable Systematic Error (as appropriate) (for the avoidance of doubt, being the period referred to in paragraph 4.6(a)(i) above) shall be adjusted by [TranseoNCG](#) in accordance with the provisions of paragraph 4.6(a)(iii);
- (iii) [TranseoNCG](#) shall (consistently with the provisions of paragraph 3.2) calculate the adjustment referred to in paragraph 4.6(a)(ii) so as to provide a corrected value for volume flows and energy flows as if there had been no such Constant Systematic Error or Variable Systematic Error and [TranseoNCG](#) shall notify BGE of such adjustment with its validation report in accordance with the provisions of paragraph 4.7.

- (b) The amount by which the adjusted quantity determined to have been offtaken on any Day differs from the quantity originally determined to have been offtaken on such Day, pursuant to any validation or resolution of any dispute in relation thereto, shall be treated as the "Aggregate Daily Reconciliation Quantity" in respect of CSPX and CSPY on such Day and the provisions of the [CSEP Moffat](#) Ancillary Agreement and the Network Code in respect of CSEP Reconciliation (including any charges payable as a consequence of the application of such provisions) shall apply in relation thereto.
- (c) Where the BGE Supply Point Measurement Equipment is found when validated to be subject to either a Constant Systematic Error or a Variable Systematic Error in respect of volume flow and/ or energy flow, irrespective of whether the BGE Supply Point

Measurement Equipment is found to read within or outside the BGE Permitted Range, then:

- (i) the BGE Supply Point Measurement Equipment shall be assumed to have been subject to the Constant Systematic Error or Variable Systematic Error (as appropriate) during the latter half of the period since last validated and found to be within the BGE Permitted Range and not to be subject to either a Constant Systematic Error or a Variable Systematic Error or, if later, since last adjusted to correct a previous Constant Systematic Error or Variable Systematic Error or to read within the BGE Permitted Range (except in the case where it is proved that the BGE Supply Point Measurement Equipment has been subject to a Constant Systematic Error or Variable Systematic Error (as appropriate) since some other date in which case the error shall be assumed to have applied since such date);
  - (ii) for the purposes of paragraph 4.6(d), the quantities read as offtaken from the [TranseoNCG](#) System on each Day at CSPZ during the period when the BGE Supply Point Measurement Equipment is assumed to have been subject to a Constant Systematic Error or Variable Systematic Error (as appropriate) (for the avoidance of doubt, being the period referred to in paragraph 4.6(c)(i) above) shall be adjusted by BGE in accordance with the provisions of paragraph 4.6(c)(iii);
  - (iii) BGE shall (consistently with the provisions of paragraph 3.2) calculate the adjustment referred to in paragraph 4.6(c)(ii) so as to provide a corrected value for volume flows and energy flows as if there had been no such Constant Systematic Error or Variable Systematic Error and BGE shall notify [TranseoNCG](#) of such adjustment with its validation report in accordance with the provisions of paragraph 4.7.
- (d) The amount by which the adjusted quantity determined to have been offtaken on any Day differs from the quantity originally determined to have been offtaken on such Day, pursuant to any validation or resolution of any dispute in relation thereto, shall be treated as the "**Aggregate Daily Reconciliation Quantity**" in respect of CSPZ on such Day and the provisions of the [CSEP Moffat](#) Ancillary Agreement and the Network Code in respect of CSEP Reconciliation (including any charges payable as a consequence of the application of such provisions) shall apply in relation thereto.

#### 4.7

- (a) Any validation pursuant to this paragraph 4 shall be conducted by [TranseoNCG](#) in respect of the [TranseoNCG](#) Supply Point Measurement Equipment and by BGE in respect of the BGE Supply Point Measurement Equipment in each case in accordance with the provisions of paragraph 4.1. The Operator conducting the validation shall give reasonable advance notice thereof to the other Party who shall (whether itself or through an agent appointed by it) be entitled to be present.
- (b) The Operator conducting the validation shall provide a validation report to the other Party within twenty-eight (28) Days of any validation stating the results of such validation and the calculation of any adjustment to volume flows and energy flows pursuant to paragraph 4.6(a)(iii) or (as the case may be) 4.6(c)(iii).

#### 4.8

- (a) In the event that that other Party wishes to dispute such results or any such adjustment, it must notify the Operator which conducted the validation of its objection setting out the grounds for its dispute and, where applicable, its proposed alternative adjustment, within fourteen (14) Days after receiving the validation report referred to in paragraph 4.7(b). In such event paragraph 4.9 shall then apply.

- (b) In the event that the other Party does not dispute such results or adjustment in accordance with the foregoing provisions of this paragraph 4.8, such results and any adjustment shall be deemed to be final and binding on BGE and [TranseoNKG](#) (and on all BGE Shippers and [TranseoNKG](#) Shippers) and, where applicable, the adjustments referred to in paragraph 4.6(a)(iii) or 4.6(c)(iii) (as appropriate) shall be applied in accordance with paragraph 4.6(b) or (as the case may be) 4.6(d).
  - (c) Provided that it was given reasonable advance notice of a validation in accordance with paragraph 4.7, the other Party shall not be entitled to dispute the results of, or any adjustment set out in, the resultant validation report solely on the ground that it did not attend. such validation.
- 4.9 At the request of either BGE or [TranseoNKG](#), BGE and [TranseoNKG](#) shall meet and discuss and endeavour to settle any dispute or failure to agree arising from the application of the provisions of this paragraph 4 and if within thirty (30) Days after such request they shall have been unable to agree, the matter may be referred to an expert for determination (at the request of either BGE or [TranseoNKG](#)) in accordance with the provisions of clause 12.

## 5 Not Used

## 6 Inspection Rights

Either Party (the "first" Party) shall have the right, upon giving reasonable notice to the other Party, to inspect that other Party's Supply Point Measurement Equipment, charts and other measurement or test data, but the reading, calibration and adjustment of that other Party's Supply Point Measurement Equipment and the changing of any charts shall be carried out by that other Party who shall preserve all original test data, charts and other similar records for a period of three (3) years and shall make a copy thereof available to the first Party upon request.

## 7 Calorific Value

The Calorific Value of the gas offtaken from the System at CSPX and CSPY shall be determined by the [TranseoNKG](#) Equipment, and the Calorific Value of the gas offtaken from the System at CSPZ shall be determined by the BGE Equipment.

## 8 Repeat Signals

- (a) The following repeat signals shall be provided in respect of CSPX and CSPY:
  - (i) Repeat signals to be provided by [TranseoNKG](#) to BGE:  
CV, RD, instantaneous volume flow, instantaneous energy flow, integrated volume flow, integrated energy flow, delivery pressure to BGE. These are provided over two routes, one hard wired and the other over an RS 485 data link. Also provided is gas composition and the status of remote block valves 03 and 51 over the data link. The former may not be required once the second link is functional.
  - (ii) Repeat signals to be provided by BGE to [TranseoNKG](#):  
Status of block valve Beat-01 over the data link.
- (b) The following repeat signals shall be provided in respect of CSPZ:
  - (i) Repeat signals to be provided by [TranseoNKG](#) to BGE:

Status of two block valves, two delivery pressures.

- (ii) Repeat signals to be provided by BGE to [TranseoNCGG](#):

CV, RD, instantaneous volume flow, instantaneous energy flow, integrated volume flow, integrated energy flow, meter fail alarm.

- (c) In respect of the CSEP, BGE's meter reads are to be transmitted immediately to [TranseoNCGG](#) for [TranseoNCGG](#) to aggregate with the [TranseoNCGG](#) meter reads.

## Part 2 - Measurement Failure

1 If during any part of any Day any part of the Supply Point Measurement Equipment is not adequately operational, the quantity of gas offtaken from the System at the relevant CSP(s) during such time will be deemed to be such quantity as may be agreed between BGE and [TranseoNCGG](#), in both cases acting reasonably and using such alternative measurements for the derivation of such quantity of gas as are set out in Annex E (and having regard to the provisions of paragraphs 2 and 3 below).

2

- (a) For [TranseoNCGG](#) Meter failure, recourse to the relevant orifice differential pressures, meter pressure, meter temperature and calorific value should be made to manually determine flow through the meter.
- (b) For BGE Meter failure, recourse to the relevant uncorrected meter reading, meter pressure, meter temperature and calorific value should be made to manually determine flow through the meter.

3

- (a) For [TranseoNCGG](#) Equipment failure, recourse to the BGE Equipment should be made to determine the calorific value of gas measured by the [TranseoNCGG](#) Meters.
- (b) For BGE Equipment failure, recourse to the [TranseoNCGG](#) Equipment should be made to determine the calorific value of gas measured by the BGE Meters.
- (c) In the event of both [TranseoNCGG](#) Equipment failure and BGE Equipment failure, recourse to such alternative equipment on the [TranseoNCGG](#) System as shall be determined by [TranseoNCGG](#) should be made to determine the calorific value of gas measured by the [TranseoNCGG](#) Meters and the BGE Meters.

4 In the event that no agreement is reached pursuant to the provisions of paragraph 1 above by the Exit Close-out Date, the quantity of gas offtaken on that Day shall be the same as the quantity of gas offtaken on the same Day in the previous week at (in the case of [TranseoNCGG](#) Meter Failure) CSPX and CSPY and (in the case of BGE Meter Failure) CSPZ.

## Part 3 - Supply Point Measurement Equipment Permitted Ranges

1 The [TranseoNCGG](#) Permitted Range in respect of the [TranseoNCGG](#) Supply Point Measurement Equipment is as set out in Table 1 below for all flow rates from 6% to 100% of the Maximum Daily Flow Rate. The Maximum Daily Flow Rate is 26MCM (0.2817TWh) at an assumed Gross Calorific Value for that Day of 40 MJ/m<sup>3</sup>. In the event that the Gross Calorific Value for a Day is greater than or less than 40 MJ/m<sup>3</sup>, the value attributed to the Maximum Daily Flow Rate shall be adjusted accordingly.

### TABLE 1- [TRANSCONCGG](#) SUPPLY POINT MEASUREMENT EQUIPMENT

## UNCERTAINTY

Quantity	TranseoNGG Permitted Range (at flow rates from 6% to 100% of Maximum Daily Flow Rate)
Volume Flow Rates (MCM) Energy Flow Rates (kWh) at 40 MJ/m <sup>3</sup>	± 1.0% ± 1.1%

- 2 The BGE Permitted Range in respect of the BGE Supply Point Measurement Equipment is as set out in Table 2 below for all flow rates from 6% to 100% of the Maximum Daily Flow Rate. The Maximum Daily Flow Rate is 13 MCM (0.1444 TWh) at an assumed Gross Calorific Value for that Day of 40 MJ/m<sup>3</sup>. In the event that the Gross Calorific Value for a Day is greater than or less than 40 MJ/m<sup>3</sup>, the value attributed to the Maximum Daily Flow Rate shall be adjusted accordingly.

**TABLE 2 - BGE SUPPLY POINT MEASUREMENT EQUIPMENT UNCERTAINTY**

Quantity	TranseoNGG Permitted Range (at flow rates from 6% to 100% of Maximum Daily Flow Rate)
Volume Flow Rates (MCM) Energy Flow Rates (kWh) at 40 MJ/m <sup>3</sup>	± 1.0% ± 1.1%

- 3 For the avoidance of doubt, the Maximum Daily Flow Rates being the amounts aggregated in paragraphs 1 and 2 do not constitute for the purposes of the Network Code or otherwise an indication of the available capacity in the TranseoNGG System at the CSEP in respect of the CSEP Fiscal Metering System (FMS) (being the metering system at which all natural gas shall be measured or analysed in accordance with the terms of this Agreement).

## ANNEX D - TECHNICAL INTERPRETATION

In this Agreement the following terms have the following meanings:

**"bar"**: the bar as defined in ISO 1000- 1981(E);

**"calorific value"**: that number of Megajoules produced by the complete combustion at a constant absolute pressure of 1.01325 bar of 1 Cubic Metre of gas at a temperature of 15°C with excess air at the same temperature and pressure as the gas when the products of combustion are cooled to 15°C and when the water formed by combustion is condensed to the liquid state and the products of combustion contain the same total mass of water vapour as the gas and air before combustion; and for the avoidance of doubt calorific value shall be REAL as defined in ISO 6976-1:1983(E);

**"Cubic Metre"** or "**m<sup>3</sup>**": when applied to gas, that amount of gas which at a temperature of 15°C and an absolute pressure of 1.01325 bar and being free of water vapour occupies one cubic metre;

**"degree Celsius"** and "**C**": the particular interval between the temperature in Kelvin and the temperature 273.15 Kelvin as defined in ISO 1000-1981(E);

**"gauge"**: when used in relation to pressure, the pressure in excess of 1 standard atmosphere where 1 standard atmosphere is 1.01325 bar;

**"hour"**: the hour as defined in ISO 1000- 1981(E);

**"Joule"**; the joule as defined in ISO 1000- 1981(E);

**"kilogram"**: the kilogram as defined in ISO 11000- 1981(E);

**"kWh"**: 3,600,000 Joules;

**"MCM"**: 1,000,000 Cubic Metres;

**"Megajoule"** or "**MJ**": 1,000,000 Joules;

**"metre"**: the metre as defined in ISO 1000- 1981(E); "**KM**": 1,000,000MJ;

**"MW"**: 1,000,000 Watts;

**"MWh"**: 1,000 kWh;

**"second"**: the second as defined in ISO 1000- 1981(E);

**"TWh"**: 1,000,000 MWh; and

**"Watt"**: 1 Joule per second,



## ANNEX E - OPERATING PROCEDURES

### 1 INTRODUCTION

- 1.1 This Annex contains the operating procedures (these "Procedures") for giving effect to certain provisions of the Agreement and provides, amongst other things, for the exchange of gas flow related information between [TranseoNKG](#) and BGE so as to facilitate the safe and efficient operation of the [TranseoNKG](#) Facilities and the BGE Facilities.
- 1.2 These Procedures shall be binding on [TranseoNKG](#) and BGE unless they expressly provide that they are not to be binding; but in the event of any conflict between any of these Procedures and any other provision of the Agreement, such other provision of the Agreement shall prevail.
- 1.3 This Annex may only be amended in writing, signed by the duly authorised representatives of both [TranseoNKG](#) and BGE.

### 2 DEFINITIONS

- 2.1 In this Annex:

**"BGE Shift Representative"** shall mean the person whose job description and contact details are set out in Appendix A hereto, or the person with such other job description and/or contact details as may be advised by BGE to [TranseoNKG](#) in writing from time to time (it being acknowledged that, to provide 24 hour cover, the BGE Shift Representative shall be a different individual person on different days and at different times of the day);

**"BGE Supply Point Measurement Equipment"** shall have the meaning given to it in Annex C;

**"Supply Point Measurement Equipment"** shall have the meaning given to it in Annex C;

**"[TranseoNKG](#) Shift Representative"** shall mean the person whose job description and contact details are set out in Appendix A hereto, or the person with such other job description and/or contact details as may be advised by [TranseoNKG](#) to BGE in writing from time to time (it being acknowledged that, to provide 24 hour cover, the [TranseoNKG](#) Shift Representative shall be a different individual person on different days and at different times of the day); and

**"[TranseoNKG](#) Supply Point Measurement Equipment"** shall have the meaning given to it in Annex C.

- 2.2 All other capitalised terms shall have the meanings given to them in the Agreement unless the context otherwise requires.

### 3 OPERATIONAL MATTERS

#### 3.1 Form of Communication

Notices served by facsimile in accordance with these Procedures shall be deemed received at the time of receipt by the sender of a transmission report showing transmission in full to the correct number without any error message.

Communications made by telephone in accordance with these Procedures shall be deemed made at the time the call was made to the correct number provided that both persons on the call confirm that they are duly authorised to make or receive (as the case may be) such call. It

is acknowledged and agreed that such telephone conversations may be recorded and the recordings used as evidence of their content.

For the avoidance of any doubt, the provisions of clause 14.4 of the Agreement shall not apply in respect of operational communications made in accordance with these Procedures.

### 3.2 Notices

BGE and/or [TranseeNKG](#) (as the context may require) shall issue operational notices in the manner and form set out in Table 1 below and otherwise as set out in these Procedures.

[BGE and NKG agree that when arrangements for electronic communication have been finalised they will vary Table 1 below accordingly.](#)

**Table 1**

Type of Notice	Means of Communication	Form of Notice
Exit Flow Profile (including revisions to an Exit Flow Profile) (an Exit Flow Profile being referred to in these Procedures as an "OPN")	Facsimile on behalf of <a href="#">TranseeNKG</a> Shippers to <a href="#">TranseeNKG</a> Shift Representative]	As per Appendix A to Annex B-2
Rejection Notice issued pursuant to paragraph 2.6 of Annex B-2 (inadequate period of notice)	Facsimile to BGE Shift Representative and <a href="#">TranseeNKG</a> Shippers ( <del>or agent</del> )	As per Appendix B to this Annex E (or such other form as may be notified by <a href="#">TranseeNKG</a> to BGE upon not less than 30 days' written notice)
Notification of invalid notice in accordance with paragraph 2.9 of Annex B-2	Facsimile to BGE Shift Representative (if the person submitting the OPN)	As per Appendix C to this Annex E (or such other form as may be notified by <a href="#">TranseeNKG</a> to BGE upon not less than 30 days' written notice)
Curtailement Notice issued pursuant to paragraph 5.5(a) of Annex B-2 (flow request above Flow Rate Change Limit)	Facsimile to BGE Shift Representative and <a href="#">TranseeNKG</a> Shippers ( <del>or agent</del> )	As per Appendix D to this Annex E (or such other form as may be notified by <a href="#">TranseeNKG</a> to BGE upon not less than 30 days' written notice)
Curtailement Notice issued pursuant to paragraph 5.5(b) of Annex B-2 (flow request above Available Firm Flow Rate) (an Interruption Notice for the purposes of the <a href="#">CSEP Moffat</a> Ancillary Agreement)	Facsimile to BGE Shift Representative and <a href="#">TranseeNKG</a> Shippers ( <del>or agent</del> )	As per Appendix E to this Annex E (or such other form as may be notified by <a href="#">TranseeNKG</a> to BGE upon not less than 30 days' written notice)
Curtailement Notice issued pursuant to paragraph 5.5(c) of Annex B-2 (notice requiring revision of a previously accepted profile above the Flow Rate Change Limit)	Facsimile to BGE Shift Representative and <a href="#">TranseeNKG</a> Shippers ( <del>or agent</del> )	As per Appendix F to this Annex E (or such other form as may be notified by <a href="#">TranseeNKG</a> to BGE upon not less than 30 days' written notice)
Curtailement Notice issued pursuant to paragraph 5.5(d) of	Facsimile to BGE Shift Representative and	As per Appendix E to this Annex E (or such other form as may be

Annex B-2 (notice requiring revision of a previously accepted profile above the Available Firm Flow Rate) (an Interruption Notice for the purposes of the <a href="#">CSEP/Moffat Ancillary Agreement</a> )	<del>Transeo</del> <a href="#">NGG</a> Shippers ( <del>or agent</del> )	notified by <del>Transeo</del> <a href="#">NGG</a> to BGE upon not less than 30 days' written notice)
Curtailed Notice issued pursuant to paragraph 5.5(e) of Annex B-2 (notice requiring reduction below the Available Firm Flow Rate in emergency circumstances)	Facsimile to BGE Shift Representative and <del>Transeo</del> <a href="#">NGG</a> Shippers ( <del>or agent</del> )	As per Appendix G to this Annex E (or such other form as may be notified by <del>Transeo</del> <a href="#">NGG</a> to BGE upon not less than 30 days' written notice)
Notice issued pursuant to paragraph 5.10 of Annex B-2 lifting requirement for a reduced flow	Facsimile to BGE Shift Representative and <del>Transeo</del> <a href="#">NGG</a> Shippers ( <del>or agent</del> )	As per Appendix H to this Annex E (or such other form as may be notified by <del>Transeo</del> <a href="#">NGG</a> to BGE upon not less than 30 days' written notice)

### 3.3 Confirmation of [Daily Measured](#) Quantities

~~Transeo~~[NGG](#) shall, from the Day after the relevant Gas Flow Day until the Exit Close-out Date by 11:00 hours provide to [BGE and](#) the agent of the ~~Transeo~~[NGG](#) Shippers details or revised details of the measured quantity of gas offtaken from the CSEP on that Gas Flow Day. Such notification shall be in the form set out in Appendix I to this Annex E or such other form as may be notified by ~~Transeo~~[NGG](#) upon not less than 30 days' written notice. ~~Transeo~~

### [3.4](#) [NGG Shipper Exit allocations](#)

[NGG](#) Shippers or their agent shall provide to ~~Transeo~~[NGG](#) Exit Allocation Statements and ~~Transeo~~[NGG](#) shall provide details of quantities determined as UDQOs to Users in each case in accordance with the terms of the [CSEP/Moffat](#) Ancillary Agreement.

### [3.5](#) ~~3.4~~ [Gas Flow, Pressure and Quality](#)

Subject to each Operator's duty of confidentiality to any third party, the ~~Transeo~~[NGG](#) Shift Representative and the BGE Shift Representative shall at all times keep the other informed by telephone of all matters likely to have, or which are already having, a significant effect on gas flow, pressure or quality at the Connected Systems Points. Each Operator will use reasonable endeavours to give as much notice to the other as practicable of any of such matters.

Upon an unforeseen change in gas flow, pressure or quality, the relevant Operator shall inform the other by telephone of the nature and estimated duration of the change as soon as reasonably practicable.

### [3.6](#) ~~3.5~~ [Beattock Compressor Station](#)

The BGE Shift Representative shall notify the ~~Transeo~~[NGG](#) Shift Representative by telephone as soon as reasonably practicable of any changes in the operation of the Beattock compressor station which may affect the offtake of gas from the ~~Transeo~~[NGG](#) System at the Connected Systems Points. Such notification shall include details of the nature of the changes at Beattock and their estimated duration.

### [3.7](#) ~~3.6~~ [Planned Maintenance](#)

Representatives of [TranseeNGG](#) and BGE will liaise in March and September of each year (or as may otherwise be agreed) to discuss and where practicable co-ordinate their respective planned maintenance programmes, emergency shut down tests, pipeline operations, and procedures associated with these activities and shall provide all other relevant information to assist the integrity and safety of the [TranseeNGG](#) System and the BGE System.

Daily flow rates for maintenance purposes should be discussed at these meetings and each Operator shall, where reasonably practicable, make reasonable efforts to accommodate the requirements of the other. The maintenance related daily flow rates should subsequently be detailed on the Exit Flow Profile (OPN).

### 3.8 ~~3.7~~ Measurement Failure

In the event that any part of the BGE Supply Point Measurement Equipment is not adequately operational, the BGE Shift Representative will inform the [TranseeNGG](#) Shift Representative by telephone of the nature and estimated duration of the failure as soon as reasonably practicable.

In the event that any part of the [TranseeNGG](#) Supply Point Measurement Equipment is not adequately operational the [TranseeNGG](#) Shift Representative will inform the BGE Shift Representative by telephone of the nature and estimated duration of the failure as soon as reasonably practicable.

In the event that any part of the Supply Point Measurement Equipment at any Connected Systems Point is not adequately operational, BGE will, so far as reasonably practicable, offtake gas from the [TranseeNGG](#) System at an alternative Connected Systems Point where there is no such failure.

Alternative methods of measurement in the event that any part of the Supply Point Measurement Equipment is not adequately operational are as set out in Part 2 of Annex C.

### 3.9 ~~3.8~~ Out of Specification OPNs

If BGE wishes to submit an OPN otherwise than in accordance with the requirements of Annex B-2, there is provision in paragraphs 2.5, 2.6, 5.1 and 5.2 of Annex B-2 for such requests to be considered.

### 3.10 ~~3.9~~ Safety and Emergencies

If there is an abnormal cessation in the offtake of gas from the [TranseeNGG](#) System at the Connected Systems Points, [TranseeNGG](#) may, if it deems it appropriate to safeguard the [TranseeNGG](#) System, and after discussion where practicable with representatives of BGE, close the necessary valves at the Connected Systems Points.

When the BGE System is able to resume offtaking gas the BGE Shift Representative shall telephone the [TranseeNGG](#) Shift Representative and confirm by facsimile or other agreed means that the BGE System is again capable of receiving amounts set out in the OPN. Both Operators will then co-operate in returning to normal conditions as soon as reasonably practicable.

In the event of an emergency on the [TranseeNGG](#) System requiring immediate isolation of the BGE System, [TranseeNGG](#) may close the necessary valves at the Connected Systems Points as it deems appropriate. The [TranseeNGG](#) Shift Representative shall as soon as is reasonably practicable inform the BGE Shift Representative by telephone of the reasons for, and the likely duration of, the emergency. Upon the cessation of the emergency both Operators shall co-operate with regard to the reopening of valves.

In the event of an emergency on the BGE System requiring immediate isolation of the [TranseeNGG](#) System, BGE may close the necessary valves at the Connected Systems Points as it deems appropriate. The BGE Shift Representative shall as soon as is reasonably

practicable inform the [Transeo](#)[NGG](#) Shift Representative by telephone of the reasons for, and the likely duration of, the emergency. Upon the cessation of the emergency both Operators shall co-operate with regard to the reopening of valves.

#### **4 Confidentiality**

For the avoidance of doubt, all information disclosed pursuant to these Procedures shall be subject to the confidentiality provisions in clause 8 of the Agreement.

## Appendix A - **Transeo**[NGG](#) Shift Representative and BGE Shift Representative

### **Transeo**[NGG](#) Shift Representative:

**Transeo**[NGG](#) National Control Centre  
NGT House  
Warwick Technology Park  
Gallows Hill  
Warwick  
CV34 6DA

Telephone: 00 44 (0)870 191 0631

Facsimile: 00 44 (0)870 191 0646

### **BGE** Shift Representative:

Grid Control  
PO Box 51  
Gasworks Road  
Cork  
Ireland

Telephone: 00 353 21 453 ~~4099~~[8999](#)

Facsimile: 00 353 21 ~~453-4373~~[431-1863](#)

## APPENDIX B - REJECTION NOTICE

TO: ~~MOFFAT AGENT~~ [BGE \(UK\) Ltd](#)  
~~42401863~~

FAX: 00 353 21 453

FAX BACK: GAS NATIONAL CONTROL [CENTRE](#)

FAX: +44 (0)870 191 0646

~~CC: BGE FAX: 00 353 21 453 4085~~

Further to paragraph 2.6 of Annex B-2 of the Connected. Systems Agreement (UK -Ireland Interconnector), ~~Transee~~ [NGG](#) rejects your revised Exit Flow Profile, received at ~~\*\*~~                      ~~\*\*~~ hours on ~~\*\*~~                      ~~\*\*~~, as sufficient notice was not provided.

Without imposing any obligation on it to accept any further request, it is ~~Transee~~ [NGG](#)'s current determination that it would be feasible to make gas available at the requested Exit Flow Rate at the following Flow Rate Change Time:

~~\*\*~~                      ~~\*\*~~                      hours.

Until an acceptable replacement Exit Flow Profile is provided, the prevailing Exit Flow Profile will continue to apply.

Please contact the ~~Transee~~ [NGG](#) Commercial Analyst (Tel. +44 (0)870 191 0637) if you have any queries regarding this notification.

The information contained in this fax is confidential and may be privileged. This fax is intended only for the individual named above. If you are not the intended recipient any review, dissemination or copying of this fax is prohibited. If you have received this fax by accident, please notify the sender immediately by telephone so that we can arrange for return of the original.

~~Transee~~ [National Grid Gas](#) plc Registered in England No. 2006000 Registered Office 1-3 Strand London WC2N 5EH

[NOTE: If the NGG Shippers appoint an agent then all notices in each Appendix of annex E will be sent to such agent and copied to BGE \(UK\) Ltd.](#)

**APPENDIX C - REJECTION NOTICE**

TO: ~~MOFFAT AGENT~~ BGE (UK) Ltd  
42401863

FAX: 00 353 21 453

FAX BACK GAS NATIONAL CONTROL CENTRE

FAX: +44 (0)870 191 0646

~~CC BGE FAX: 00 353 21 453 4085~~

Further to paragraph 2.9 of Annex B-2 of the Connected Systems Agreement (UK-Ireland Interconnector), ~~Transee~~ NGG rejects your Exit :Flow Profile, received at ~~\*\*~~ \*\* hours on ~~\*\*~~ \*\* as the Profile:

is not in the form of Appendix A to Annex B-2;

was not provided in accordance with the requirements of Annex B-2; or

provides for a rate of offtake which is not in compliance with any requirement of Annex B-2 as to the Exit Flow Rate.

Comments (if any):

---

If the Exit Flow Profile was an Initial Exit Flow Profile please submit a replacement one immediately. If the Exit Flow Profile was a revised Profile, the prevailing Exit Flow Profile will continue to apply.

Please contact the ~~Transee~~ NGG Commercial Analyst (Tel. +44 (0)870 191 0637) if you have any queries regarding this notification.

The information contained in this fax is confidential and may be privileged. This fax is intended only for the individual named above. If you are not the intended recipient any review, dissemination or copying of this fax is prohibited. If you have received this fax by accident, please notify the sender immediately by telephone so that we can arrange for return of the original.

~~Transee~~ National Grid Gas plc Registered in England No. 2006000 Registered Office 1-3 Strand London WC2N 5EH



**APPENDIX D - CURTAILMENT NOTICE**

TO: ~~MOFFAT AGENT~~ [BGE \(UK\) Ltd](#)  
~~42401863~~

FAX: 00 353 21 453

FAX BACK GAS NATIONAL CONTROL CENTRE

FAX: +44 (0)870 191 0646

~~CC BGE FAX: 00 353 21 453 4085~~

Further to paragraph 5.5(a) of Annex B-2 of the Connected Systems Agreement (UK-Ireland Interconnector), ~~Transee~~ [NGG](#) rejects your Exit Flow Profile, received at ~~\*\*~~                      ~~\*\*~~ hours on ~~\*\*~~                      ~~\*\*~~ as:

(in the case of an Initial Exit Flow Profile) the Initial Exit Flow Rate or Flexed Initial Exit Flow Rate differs from the Final Preceding Day Rate by more than the Flow Rate Change Limit; or

(in the case of a revision to an Exit Flow Profile) the Exit Flow Rate or Flexed Exit Flow Rate differs from the Initial Exit Flow Rate by more than the Flow Rate Change Limit.

If the Exit Flow Profile was an Initial Exit Flow Profile please submit a replacement one immediately. If the Exit Flow Profile was a revised profile, the prevailing Exit Flow Profile will continue to apply.

Please contact the ~~Transee~~ [NGG](#) Commercial Analyst (Tel. +44 (0) 870 191 0637) if you have any queries regarding this notification.

The information contained in this fax is confidential and may be privileged. This fax is intended only for the individual named above. If you are not the intended recipient any review, dissemination or copying of this fax is prohibited. If you have received this fax by accident, please notify the sender immediately by telephone so that we can arrange for return of the original.

~~Transee~~ [National Grid Gas](#) plc Registered in England No. 2006000 Registered Office 1-3 Strand London WC2N 5EH

**APPENDIX E - CURTAILMENT NOTICE**

TO: ~~MOFFAT AGENT~~ BGE (UK) Ltd  
~~42401863~~

FAX: 00 353 21 453

FAX BACK GAS NATIONAL CONTROL CENTRE

FAX: +44 (0)870 191 0646

~~CC BGE~~ ~~FAX: 00 353 21 453 4085~~

This is an INTERRUPTION NOTICE pursuant to paragraph 5.5 (b) of Annex B-2 of the Connected Systems Agreement (UK - Ireland Interconnector) as the Exit Flow Profile received at ~~\*\*~~ \*\* hours on ~~\*\*~~ \*\*  indicates an Exit Flow Rate or Flexed Exit Flow Rate that exceeds the Available Firm Flow Rate (AFFR).

This is an INTERRUPTION NOTICE pursuant to paragraph 5.5 (d) of Annex B-2 of the Connected Systems Agreement (UK - Ireland Interconnector) as the Exit Flow Profile received at ~~\*\*~~ \*\* hours on ~~\*\*~~ \*\*  which was previously accepted by ~~Transeo~~ NGG, indicates an Exit Flow Rate or Flexed Exit Flow Rate that exceeds the Available Firm Flow Rate (AFFR).

~~NETWORK CODE~~ INTERRUPTION REQUIREMENTS: The user shall by telephone or facsimile:

~~G-6.8.3~~(a) not later than 30 minutes after this Interruption Notice is given, acknowledge receipt of that notice.

~~G-6.8.3~~(b) not later than 5 hours after this Interruption Notice is given, confirm to ~~Transeo~~ NGG that Interruption (in accordance with this notice) has taken place or will take place. Please sign the Confirmation of Interruption box below to do this and return.

INTERRUPTION REF: ~~\*\*~~ \*\*

EFFECTIVE GAS DAY: ~~\*\*~~ \*\* START TIME: ~~\*\*~~ \*\*

ESTIMATED DURATION: ~~\*\*~~ \*\*

**TRANSCONNGG SELECTED CONNECTED SYSTEM EXIT POINT FOR INTERRUPTION:**

NAME	DAYS ALREADY INTERRUPTED	REDUCE OFFTAKE TO (KWh/h)*	CONFIRMATION OF INTERRUPTION
Moffat Interconnector			

\* PLEASE DO NOT EXCEED THIS RATE UNLESS ADVISED TO DO SO VIA A NOTICE OF RESTORATION

TRANCHE As at	KWh/d	KWh Cumulative	TRANCHE(S) INTERRUPTED (X)
1			
2			
3			
4			
5			
6			
7			
8			
9			

Please contact the [TranseeNGG](#) Commercial Analyst (Tel. +44 (0)870 191 0637) if you have any queries regarding this notification.

The information contained in this fax is confidential and may be privileged. This fax is intended only for the individual named above. If you are not the intended recipient any review, dissemination or copying of this fax is prohibited. If you have received This fax by accident, please notify the sender immediately by telephone so that we can arrange for return of the original.

[TranseeNational Grid Gas](#) plc Registered in England No. 2006000 Registered Office 1-3 Strand London WC2N 5EH

**APPENDIX F - CURTAILMENT NOTICE**

TO: ~~MOFFAT AGENT~~ BGE (UK) Ltd  
42401863

FAX: 00 353 21 453

FAX BACK GAS NATIONAL CONTROL CENTRE

FAX: +44 (0)870 191 0646

~~CC BGE FAX: 00 353 21 453 4085~~

Further to paragraph 5.5(c) of Annex B-2 of the Connected Systems Agreement (UK-Ireland Interconnector), ~~Transeo~~ NGG requires a revision to your previously accepted Exit Flow Profile, received at ~~\*\*~~ \*\* hours on ~~\*\*~~ \*\*, as:

- (in the case of an Initial Exit Flow Profile) the Initial Exit Flow Rate or Flexed Initial Exit Flow Rate differs from the Final Preceding Day Rate by more than the Flow Rate Change Limit; or
- (in the case of a revision to an Exit Flow Profile) the Exit Flow Rate or Flexed Exit Flow Rate differs from the Initial Exit Flow Rate by more than the Flow Rate Change Limit.

~~Transeo~~ NGG requires that you reduce your Exit Flow Rate or Flexed Exit Flow Rate to no greater than

~~\*\*~~ \*\* kWh, by ~~\*\*~~ \*\* hours on ~~\*\*~~ \*\*

Please immediately submit a revised Exit Flow Profile accordingly.

The estimated period (which shall not bind ~~Transeo~~ NGG) for which this reduced rate is required is ~~\*\*~~ \*\*

Please contact the ~~Transeo~~ NGG Commercial Analyst (Tel. +44 (0)870 191 0637) if you have any queries regarding this notification.

The information contained in this fax is confidential and may be privileged. This fax is intended only for the individual named above. If you are not the intended recipient any review, dissemination or copying of this fax is prohibited. If you have received this fax by accident, please notify the sender, immediately by telephone so that we can arrange for return of the original.

~~Transeo~~ National Grid Gas plc Registered in England No. 2006000 Registered Office 1-3 Strand London WC2N 5EH

**APPENDIX G - EMERGENCY CURTAILMENT NOTICE**

TO: ~~MOFFAT AGENT~~ [BGE \(UK\) Ltd](#)  
~~42401863~~

FAX: 00 353 21 453

FAX BACK GAS NATIONAL CONTROL CENTRE

FAX: +44 (0)870 191 0646

~~CC BGE FAX: 00 353 21 453 4085~~

Pursuant to paragraph 5.5(e) of Annex B-2 of the Connected Systems Agreement (UK-Ireland Interconnector), ~~Transeo~~ [NGG](#) requires a reduction of the Exit Flow Rate and Flexed Exit Flow Rate below the Available Firm Flow Rate (AFFR) as follows:

Reduction required: ~~\*\*~~ \*\*

Time of reduction: ~~\*\*~~ \*\*

Estimated Period of reduction: ~~\*\*~~ \*\*

Please immediately submit a revised Exit Flow Profile in accordance with the requirements of this Curtailment Notice.

Please contact the ~~Transeo~~ [NGG](#) Commercial Analyst (Tel. +44 (0)870 191 0637) if you have any queries regarding this notification.

The information contained in this fax is confidential and may be privileged. This fax is intended only for the individual named above. If you are not the intended recipient any review, dissemination or copying of this fax is prohibited. If you have received this fax by accident, please notify the sender immediately by telephone so that we can arrange for return of the original.

~~Transeo~~ [National Grid Gas](#) plc Registered in England No. 2006000 Registered Office 1-3 Strand London WC2N 5EH

**APPENDIX H**

TO: ~~MOFFAT AGENT~~ BGE (UK) Ltd  
42401863

FAX: 00 353 21 453

FAX BACK GAS NATIONAL CONTROL CENTRE

FAX: +44 (0)870 191 0646

~~CC BGE FAX: 00 353 21 453 4085~~

This Notice is given pursuant to paragraph 5.10 of Annex B-2 of the Connected Systems Agreement (UK-Ireland Interconnector) and relates to a Curtailment Notice given under paragraph 5.5(c) or (d). The restrictions imposed by the Curtailment Notice will be lifted at the Restoration Start Time. Please sign the "Confirmation of Restoration box" below to confirm, and return to ~~Transee~~ NGG at the above facsimile number.

TRANSCO REF: ~~\*\*~~ \_\_\_\_\_ ~~\*\*~~ \_\_\_\_\_

EFFECTIVE GAS DAY: ~~\*\*~~ \_\_\_\_\_ ~~\*\*~~ \_\_\_\_\_

RESTORATION START TIME: ~~\*\*~~ \_\_\_\_\_ ~~\*\*~~ \_\_\_\_\_

**~~TRANSCO~~ NGG SELECTED CONNECTED SYSTEM EXIT POINT FOR RESTORATION:**

NAME	OFFTAKE CAN BE RESTORED AT THE RESTORATION START TIME	CONFIRMATION OF RESTORATION
MOFFAT INTERCONNECTOR		

The Exit Flow Profile submitted at ~~\*\*~~ \_\_\_\_\_ ~~\*\*~~ \_\_\_\_\_ hours on ~~\*\*~~ \_\_\_\_\_ ~~\*\*~~ \_\_\_\_\_ shall have effect from the Restoration Start Time.

Please contact the ~~Transee~~ NGG Commercial Analyst (Tel. +44 (0)870 191 0637) if you have any queries regarding this notification.

The information contained in this fax is confidential and may be privileged. This fax is intended only for the individual named above. If you are not the intended recipient any review, dissemination or copying of this fax is prohibited. If you have received this fax by accident, please notify the sender immediately by telephone so that we can arrange for return of the original.

~~Transee~~ National Grid Gas plc Registered in England No. 2006000 Registered Office 1-3 Strand London WC2N 5EH

## APPENDIX I

Gas Flow Day:

Date:

To:

~~Moffat Agent~~

BGE

Fax No: 00 353 21 453 ~~4240~~1863

Moffat

Ref:

Site Measurement (MCM):

Site Measurement (MMJ):

The information contained in this fax is confidential and may be privileged. This fax is intended only for the individual named above. If you are not the intended recipient any review, dissemination or copying of this fax is prohibited. If you have received this fax by accident, please notify the sender immediately by telephone so that we can arrange for return of the original.

~~Transee~~National Grid Gas plc Registered in England No. 2006000 Registered Office 1-3 Strand London WC2 N5EH

## **ANNEX F – NETWORK ENTRY PROVISIONS**

### **1 Scope**

- 1.1 This Annex F sets out provisions applying in respect of the System Entry Point.
- 1.2 Subject to any contrary designation by NGG pursuant to Section I1.5.2, the System Entry Point shall constitute an Aggregate System Entry Point.

### **2 Network Entry Provisions**

- 2.1 In relation to the System Entry Point:
- (a) the Connected Delivery Facility is the BGE System.
  - (b) the Individual System Entry Points comprised in the System Entry Point are the CSPs.
- 2.2 It is acknowledged and agreed that, as no physical flows of gas from the BGE System to the NGG System are permitted at the Systems Connection Point, Gas Entry Conditions, Measurement Provisions and identified points of delivery (each as referred to in Section I2.3.1(c)) are not required as Network Entry Provisions in relation to the System Entry Point.

### **3 Notification of Quantities at CSEP and SEP**

- 3.1 For the purposes of Section E1.9.1, BGE shall notify to NGG a quantity which represents the aggregate amount to be treated as having flowed on the Preceding Day:
- (a) from the NGG System to the BGE System (based on quantities which BGE determines would have flowed in the absence of any nomination of a gas flow out of the BGE System at the System Entry Point);
  - (b) from the BGE System to the NGG System (based on information provided by or on behalf of BGE Shippers nominating gas flows from the BGE System to the NGG System).
- 3.2 The net aggregate amount of the quantities notified under paragraphs 3.1 shall be equal to the measured quantity of gas offtaken on the Day as referred to in paragraph 3.3 of Annex E.
- 3.3 National Grid Gas shall have no responsibility to investigate or verify any quantity notified by BGE under paragraph 3.1.
- 3.4 The quantities notified by BGE under paragraph 3.1 will be used (in accordance with the provisions of the Moffat Ancillary Agreement and the Network Code) to determine the quantities offtaken from and delivered to the NGG System by NGG Shippers.
- 3.5 Where for the purposes of paragraph 3.4 for a Gas Flow Day in respect of which either condition in Section E2.1.7 is not satisfied and no allocation can be made in accordance with Section E2.1.8 or 2.1.9:
- (a) the quantity of gas treated as being delivered to the NGG System shall be deemed to be zero;
  - (b) the CSEP Daily Quantity Offtaken shall be the quantity determined as offtaken from the NGG System at the CSP in accordance with Annex C; and
  - (c) Section E1.9.4 shall not apply;



3.6 Where so agreed between BGE, NGG and Shippers, the notifications and determinations under paragraphs 3.1 may be made by an agent on behalf of NGG Shippers.

#### **4 Entry flows**

4.1 BGE shall ensure that there is no instantaneous physical flow of gas from the BGE System to the NGG System at the Systems Connection Point.

4.2 Without prejudice to paragraph 4.1, if such a flow of gas occurs, BGE shall ensure that as soon as possible thereafter (and in any event within the same Day) such flow is offset by an equal or greater flow of gas to the BGE System from the NGG System at the Systems Connection Point.

4.3 The Parties agree that, before either of them allows NGG Shippers or (as the case may be) BGE Shippers to nominate or be allocated net physical flows of gas from the BGE System to the NGG System at the Systems Connection Point:

- (a) this Agreement must be amended to provide for appropriate Network Entry Provisions (including those referred to in paragraph 2.2 above);
- (b) appropriate determinations will be required in respect of the price control provisions (relating to NTS Entry Capacity) in conditions of NGG's gas transporter's licence;
- (c) such amendment of this Agreement will be conditional on the making and approval of any appropriate amendments of the Moffat Ancillary Agreement.

Document comparison done by Workshare Professional on 01 July 2011 18:20:56

<b>Input:</b>	
Document 1	file://C:/Documents and Settings/Frank.Roper/Desktop/Moffat CSA Ammendment and Reinstatement Agreement 2004.DOC
Document 2	file://C:/Documents and Settings/Frank.Roper/Desktop/MOFFAT - CSA Second Amendment and Reinstatement Agreement (01.07.11).DOC
Rendering set	standard

<b>Legend:</b>	
<u>Insertion</u>	
<del>Deletion</del>	
<del>Moved from</del>	
<u>Moved to</u>	
Style change	
Format change	
<del>Moved deletion</del>	
Inserted cell	
Deleted cell	
Moved cell	
Split/Merged cell	
Padding cell	

<b>Statistics:</b>	
	Count
Insertions	581
Deletions	574
Moved from	12
Moved to	12
Style change	0
Format changed	0
Total changes	1179